

The CEBAF 22GeV Energy Upgrade

The Site

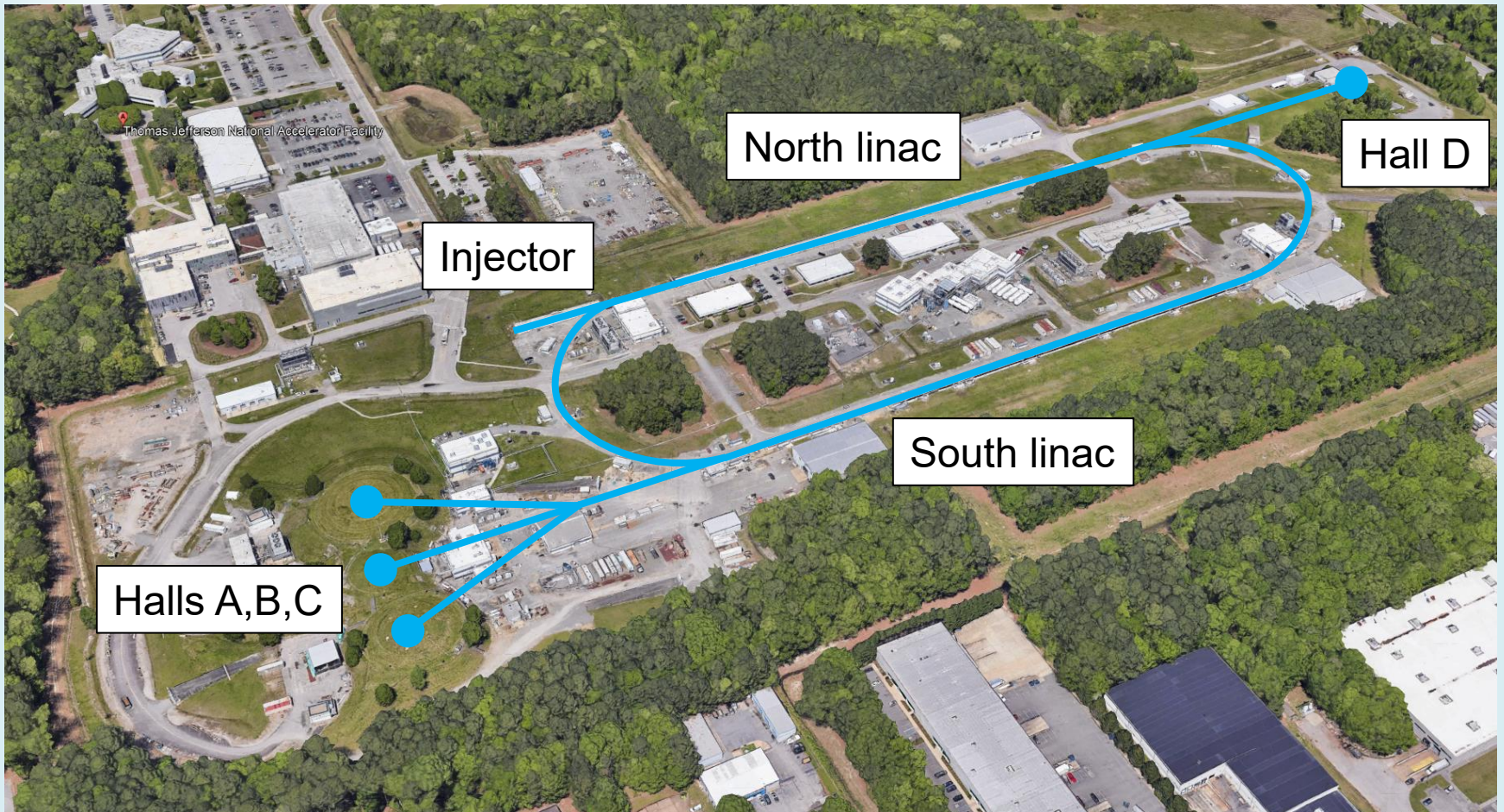

The Site



6GeV “Original” CEBAF (2000)

(Actually started from 4GeV in 1995)

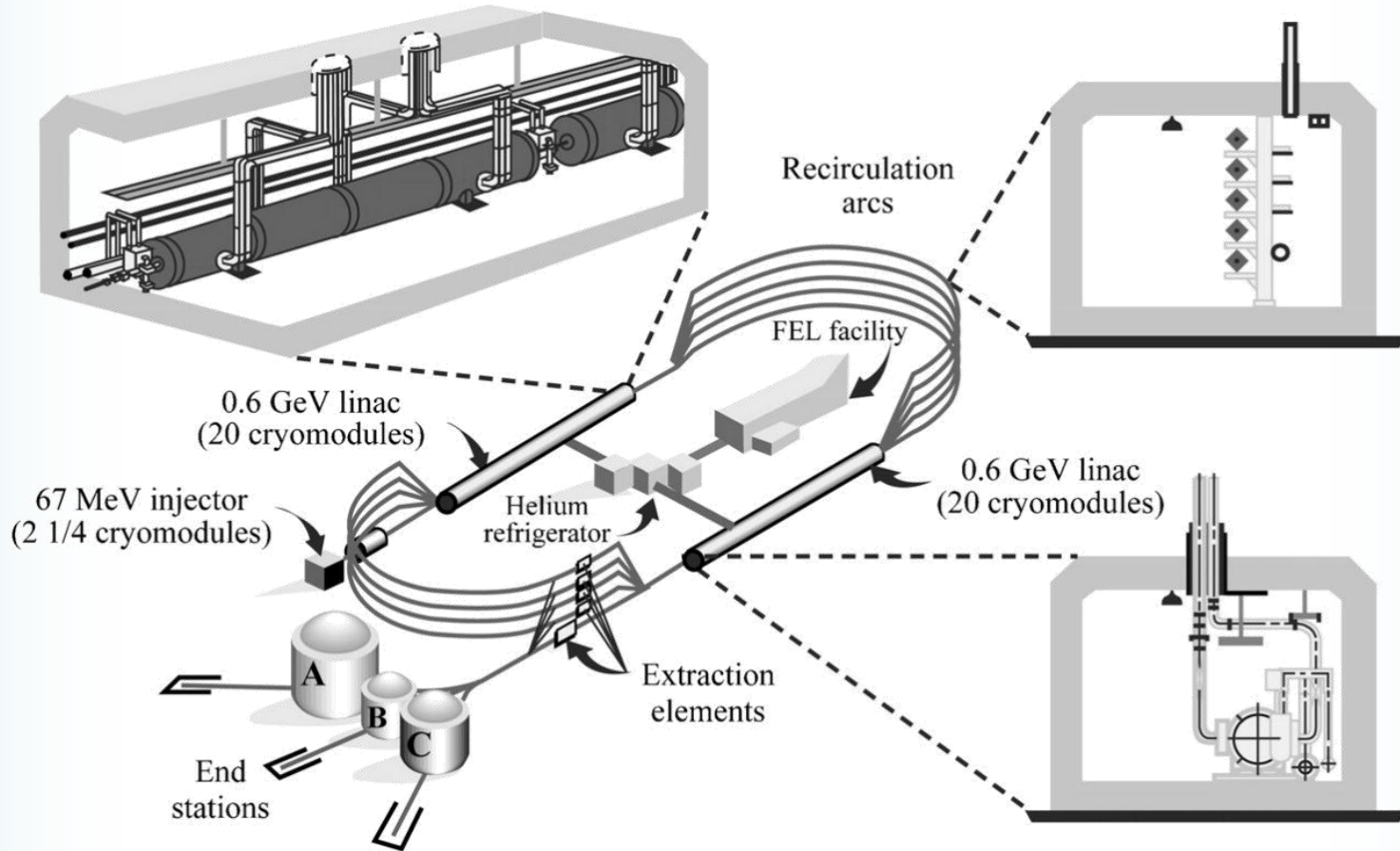

6 → 12GeV Upgrade (2017)

1.1GeV linacs
123MeV injector

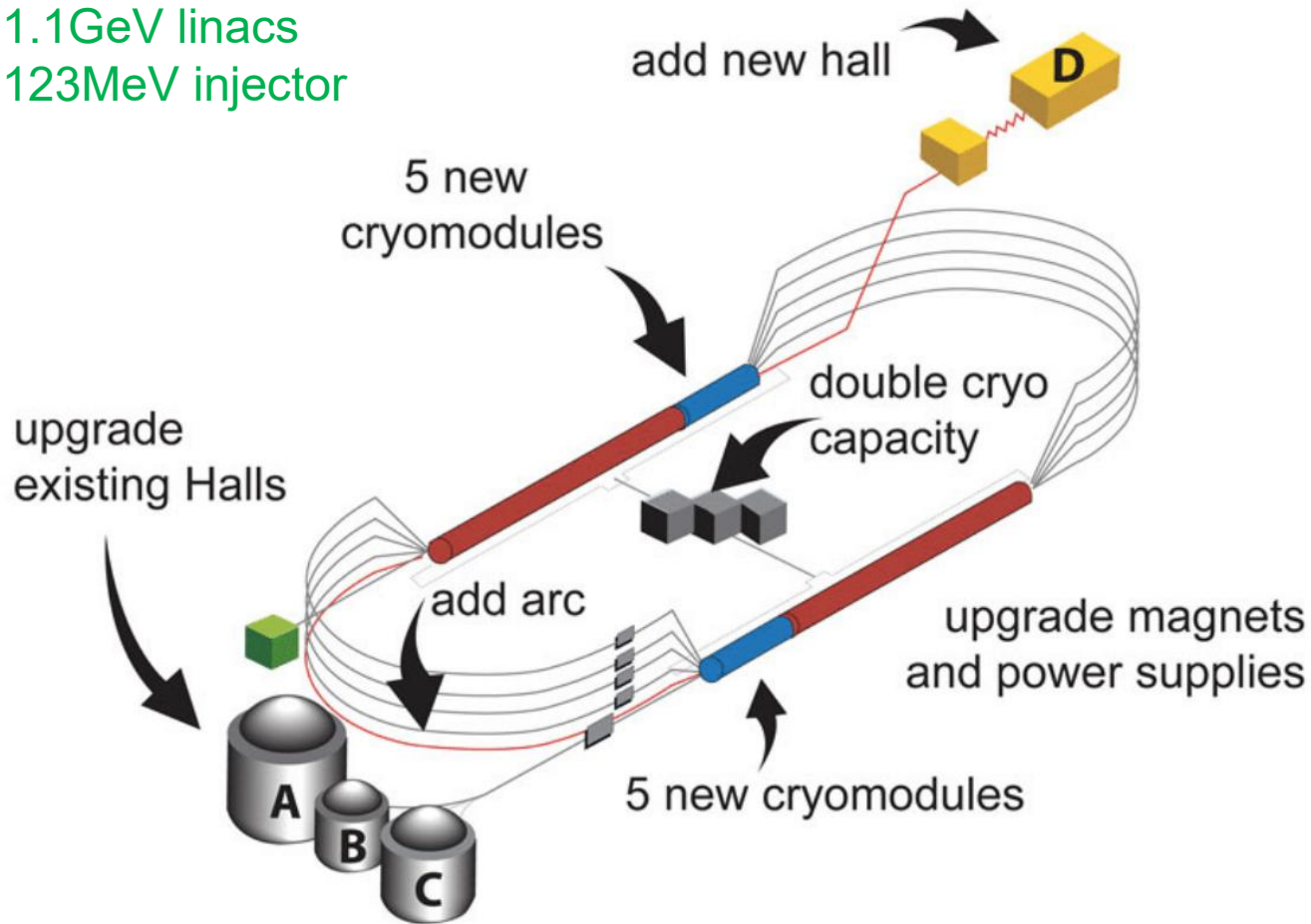

Energies of Each Turn

West arcs	East arcs
Injector = 123MeV	1.2GeV
2.3GeV	3.4GeV
4.5GeV	5.6GeV
6.7GeV	7.8GeV
8.8GeV	9.9GeV
11.0GeV = Halls A, B, C	12.0GeV = Hall D

West arcs	East arcs	SR loss per arc
Injector = 650MeV	1.7GeV	0.0070MeV
2.8GeV	3.9GeV	0.23MeV
5.0GeV	6.1GeV	1.6MeV
7.2GeV	8.3GeV	5.7MeV
9.4GeV	10.5GeV	20MeV
11.6GeV	12.6GeV	34MeV
13.7GeV	14.8GeV	39MeV
15.8GeV	16.9GeV	47MeV
17.9GeV	19.0GeV	70MeV
20.0GeV	20.9GeV	129MeV
21.9GeV = Halls A, B, C	22.9GeV = Hall D	186MeV

Above: 12GeV CEBAF

5+5 arc passes

5+6 linac passes to Hall D

Right: 22GeV upgrade

(4+6)+(4+6) arc passes

10+11 linac passes

650MeV Injector Upgrade

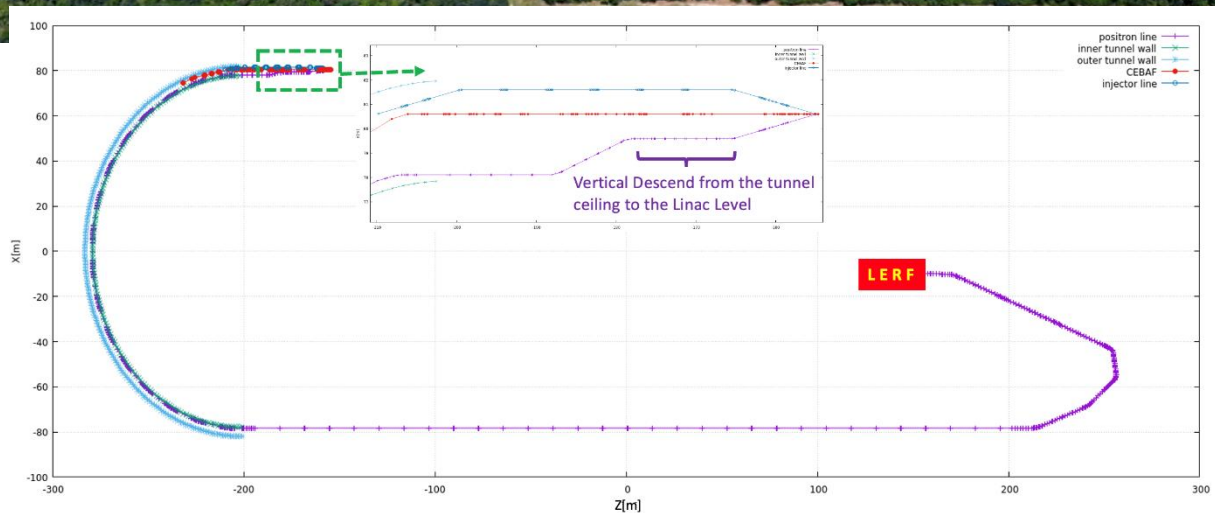

by Alex Bogacz
and Salim Ogur

650MeV Injector Upgrade

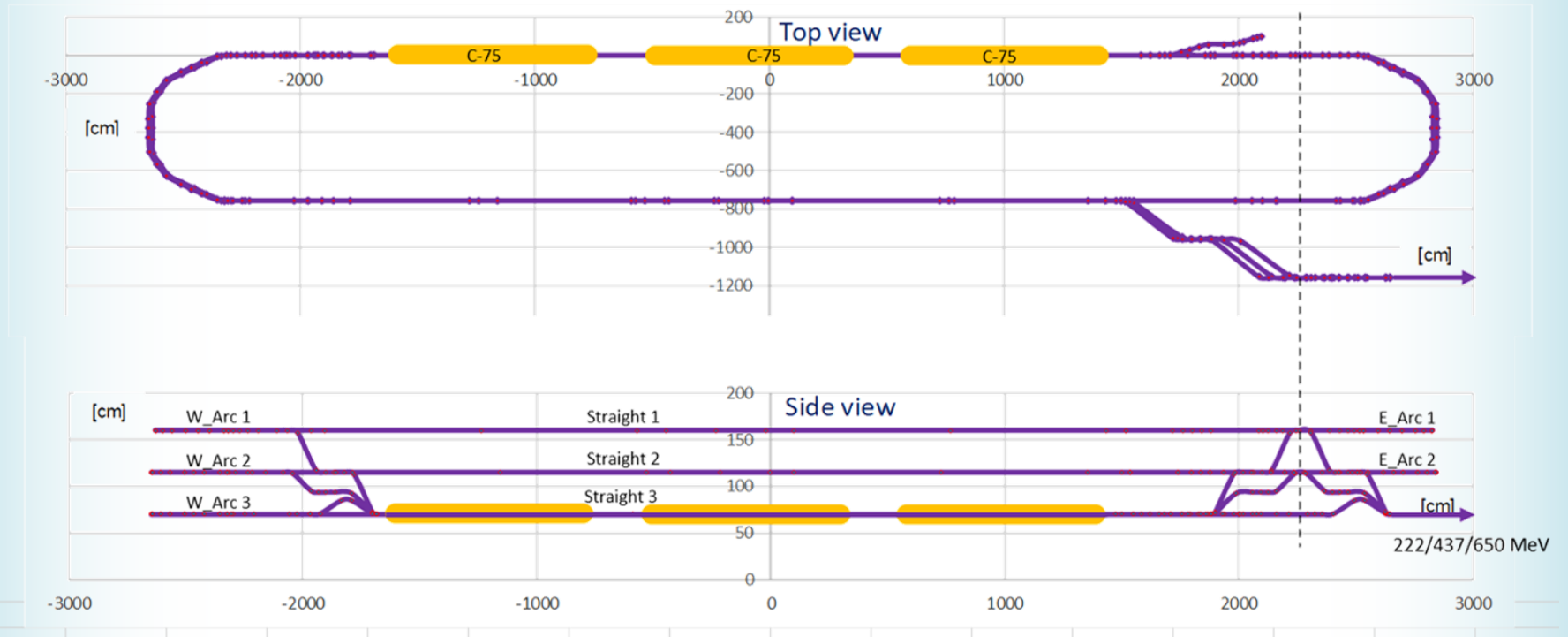

What is LERF?

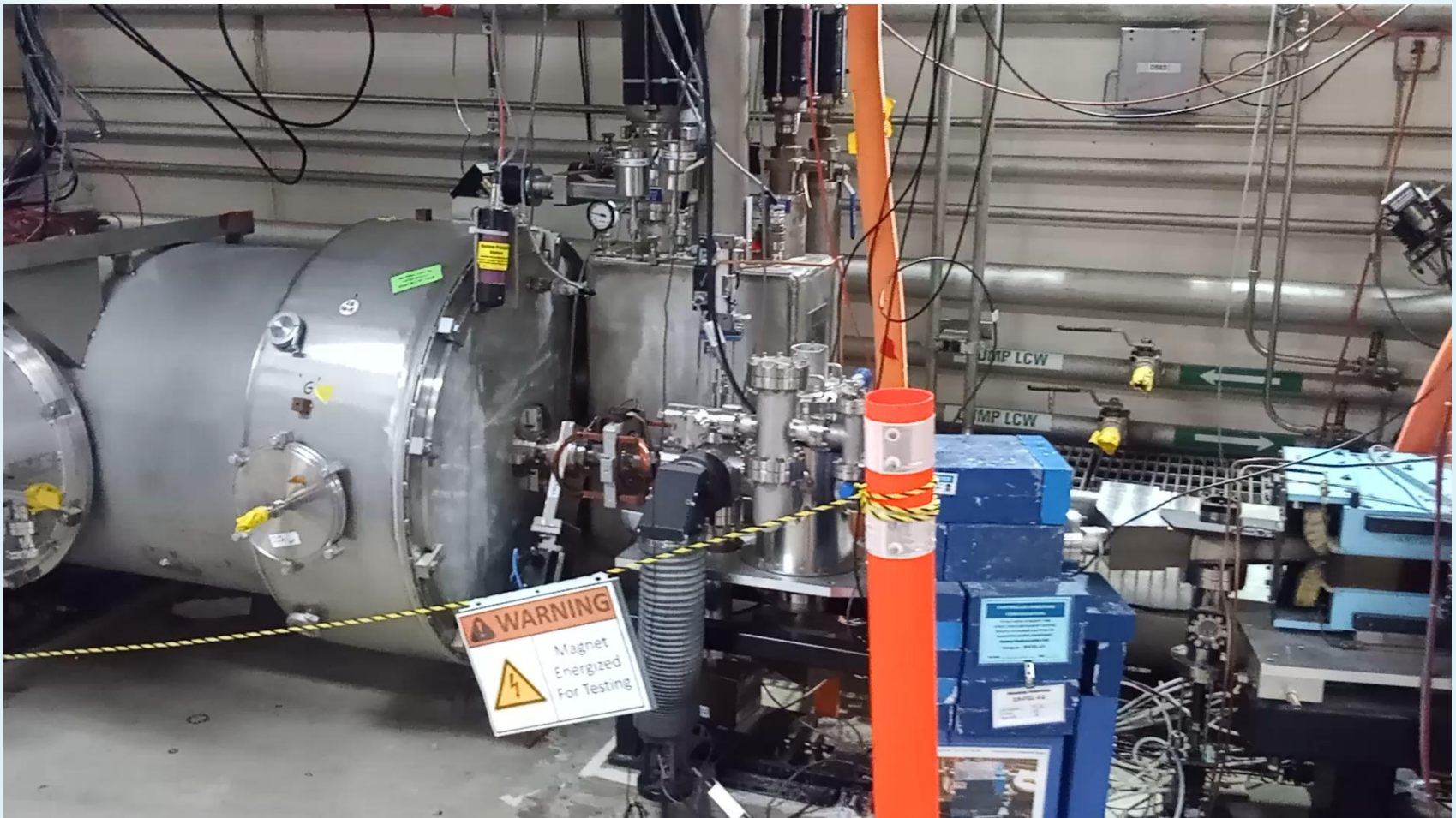

12GeV CEBAF in the Tunnel



Stacked Quadrupoles



Stacked Dipoles



Stacked Drift Spaces



CW Superconducting Linac



1497MHz
2K
Nb

Inter-tank Focussing Quadrupole

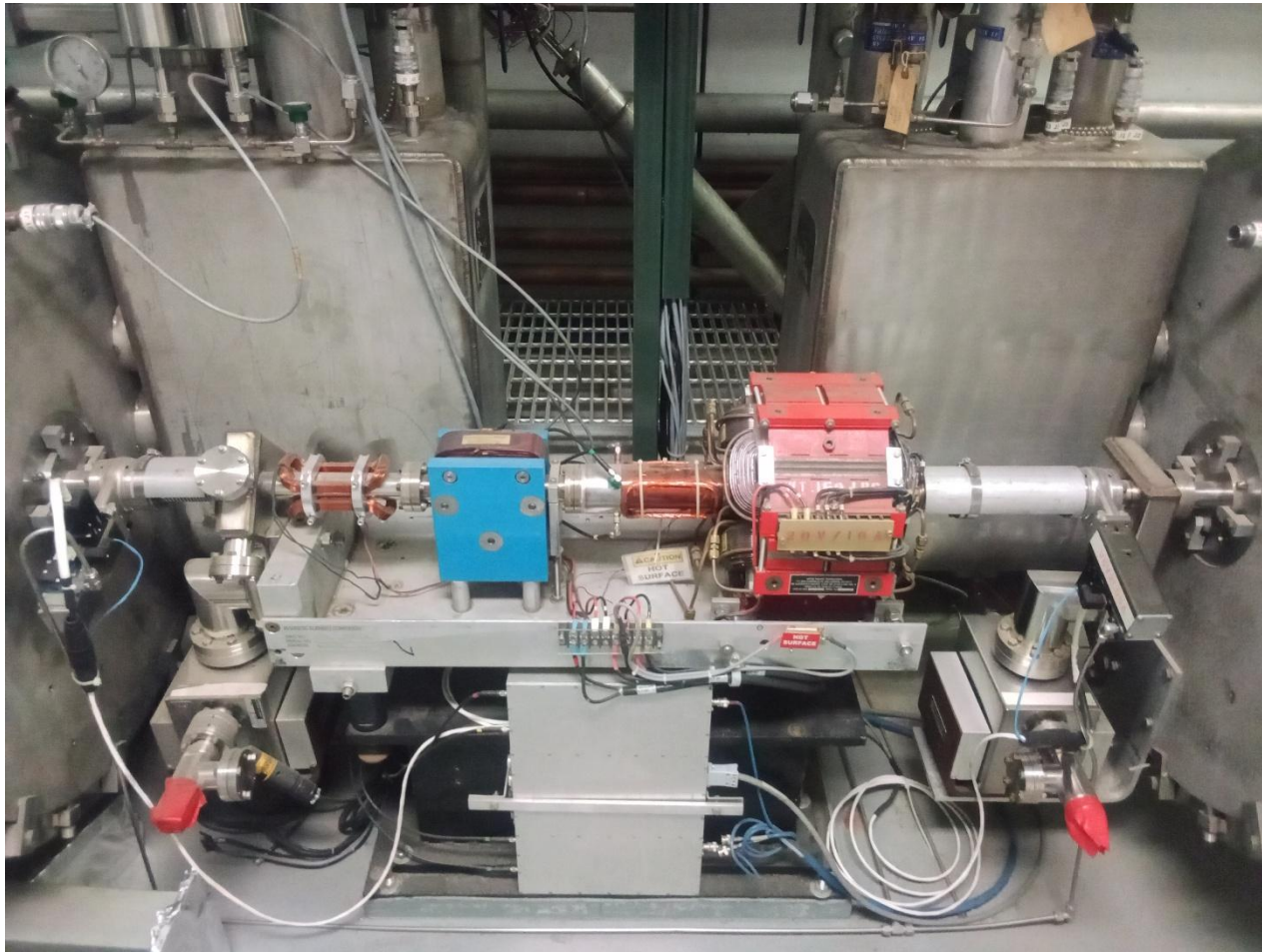

Vertical Splitting Sections



Vertical Splitting Sections



Lines to the Halls



Lines to the Halls



CEBAF 22 GeV Upgrade
Using two new FFA arcs
(Fixed-Field Alternating Gradient arcs made with permanent magnets.)

Still 1.1 GeV linacs
6 → 11 passes each

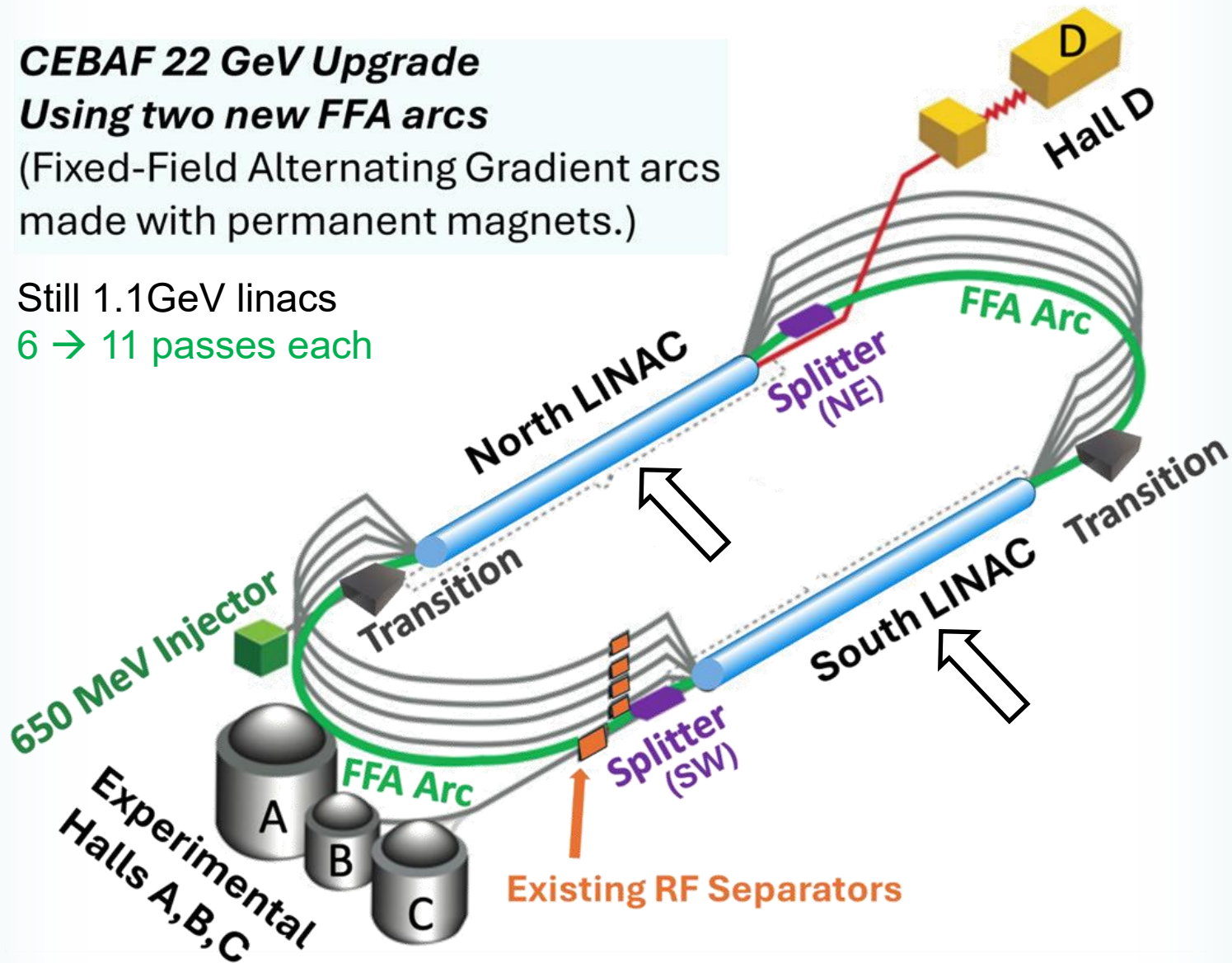

Multi-Pass Linac Optics

by Alex Bogacz

650 MeV

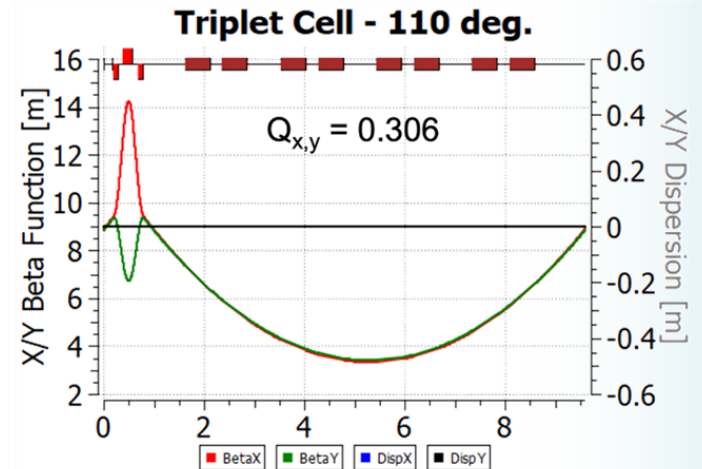
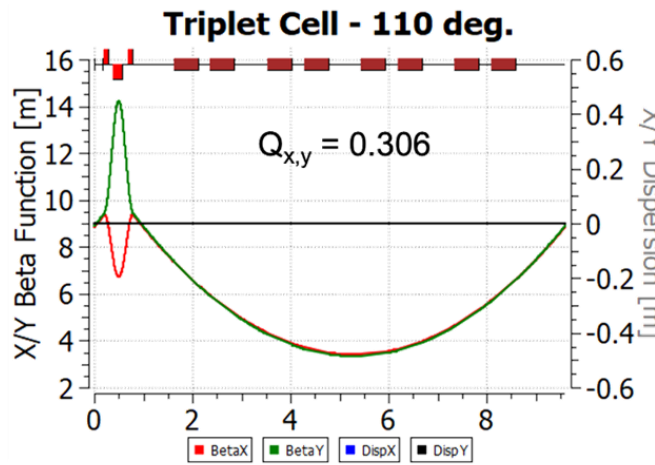

Alternating
FDF/DFD
triplets

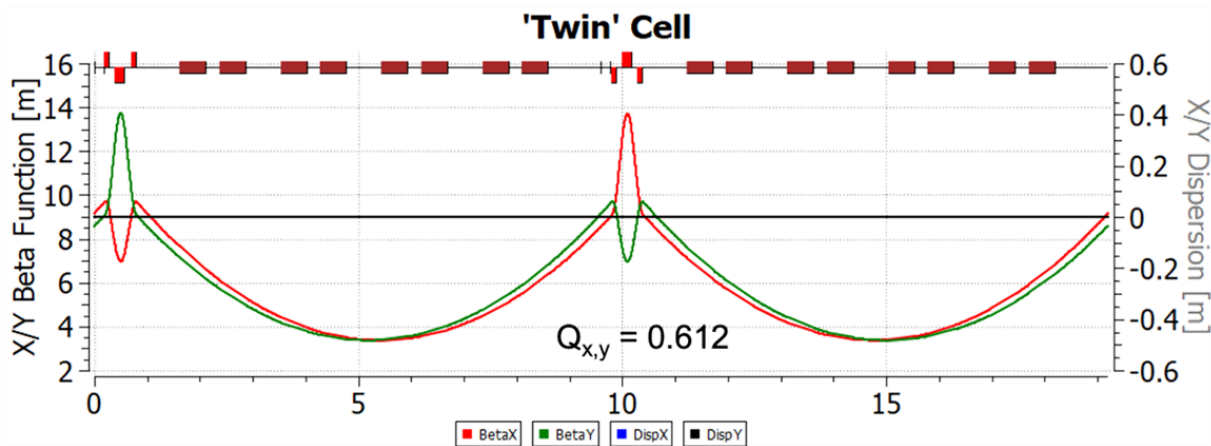

Lowest Energy Linac Passes

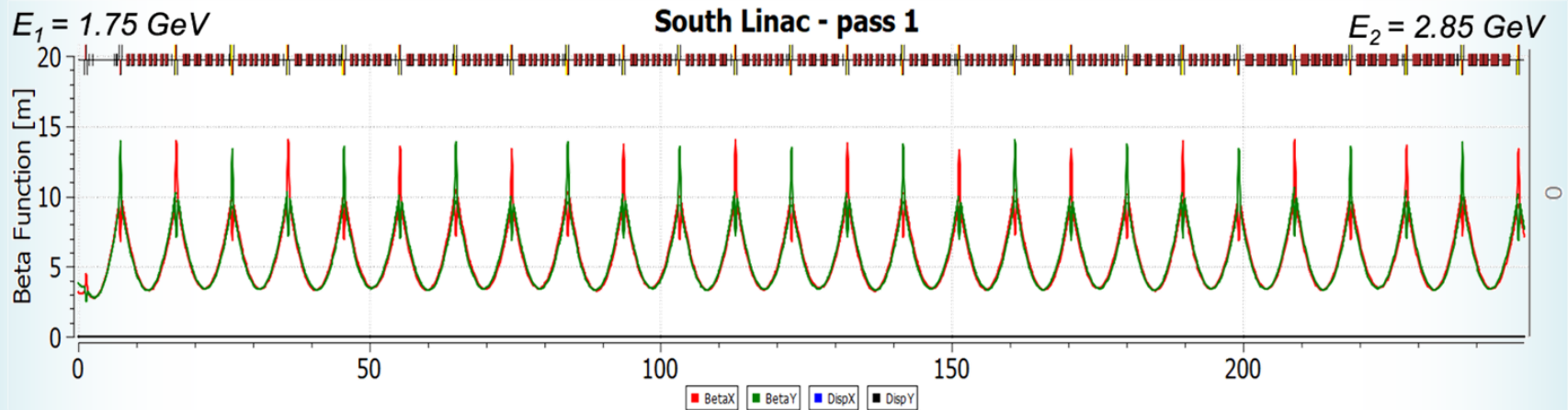
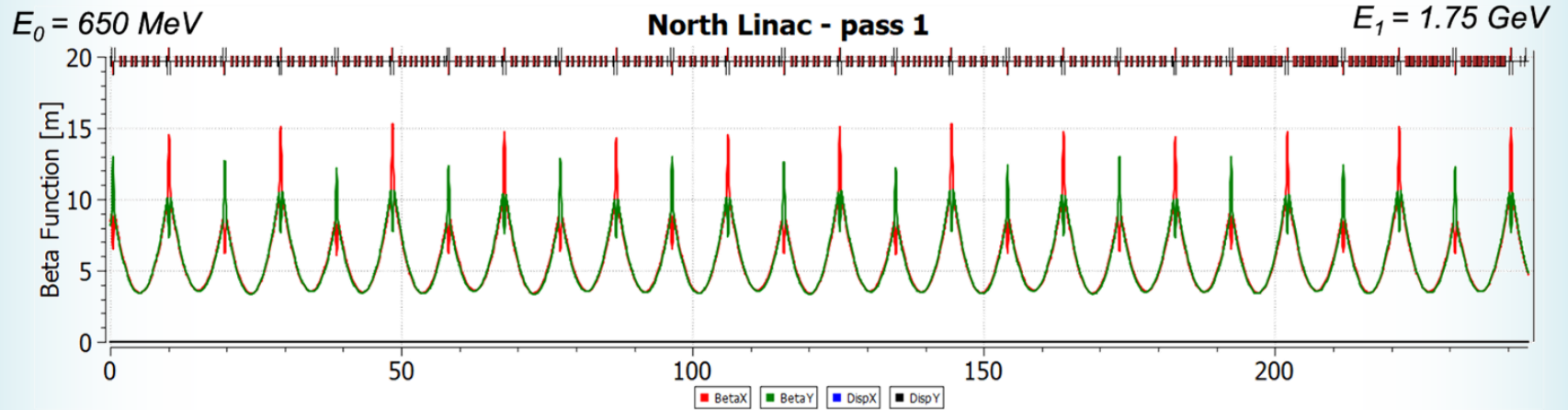

Higher Energy Linac Passes

Alternating triplets
become FODO!

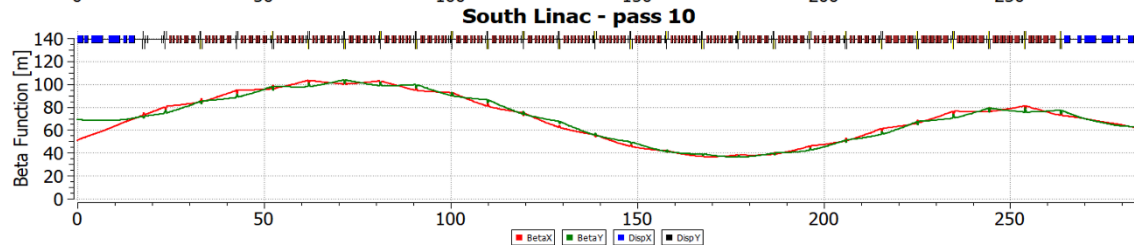
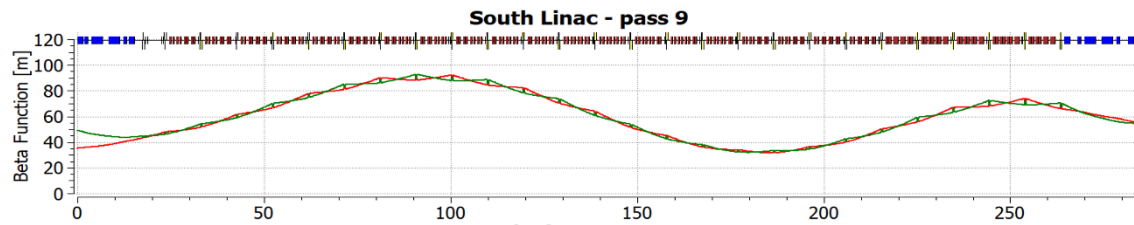
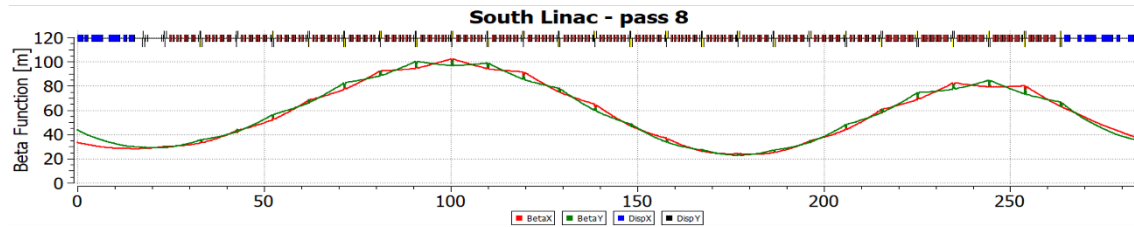
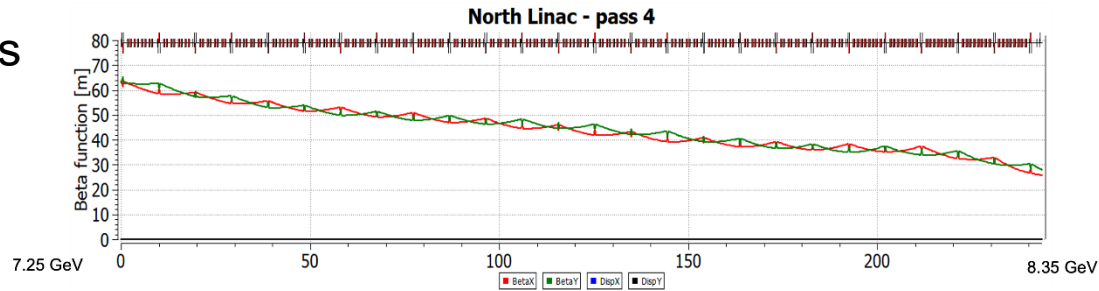

CEBAF 22 GeV Upgrade
Using two new FFA arcs
(Fixed-Field Alternating Gradient arcs made with permanent magnets.)

Still 1.1 GeV linacs
6 → 11 passes each

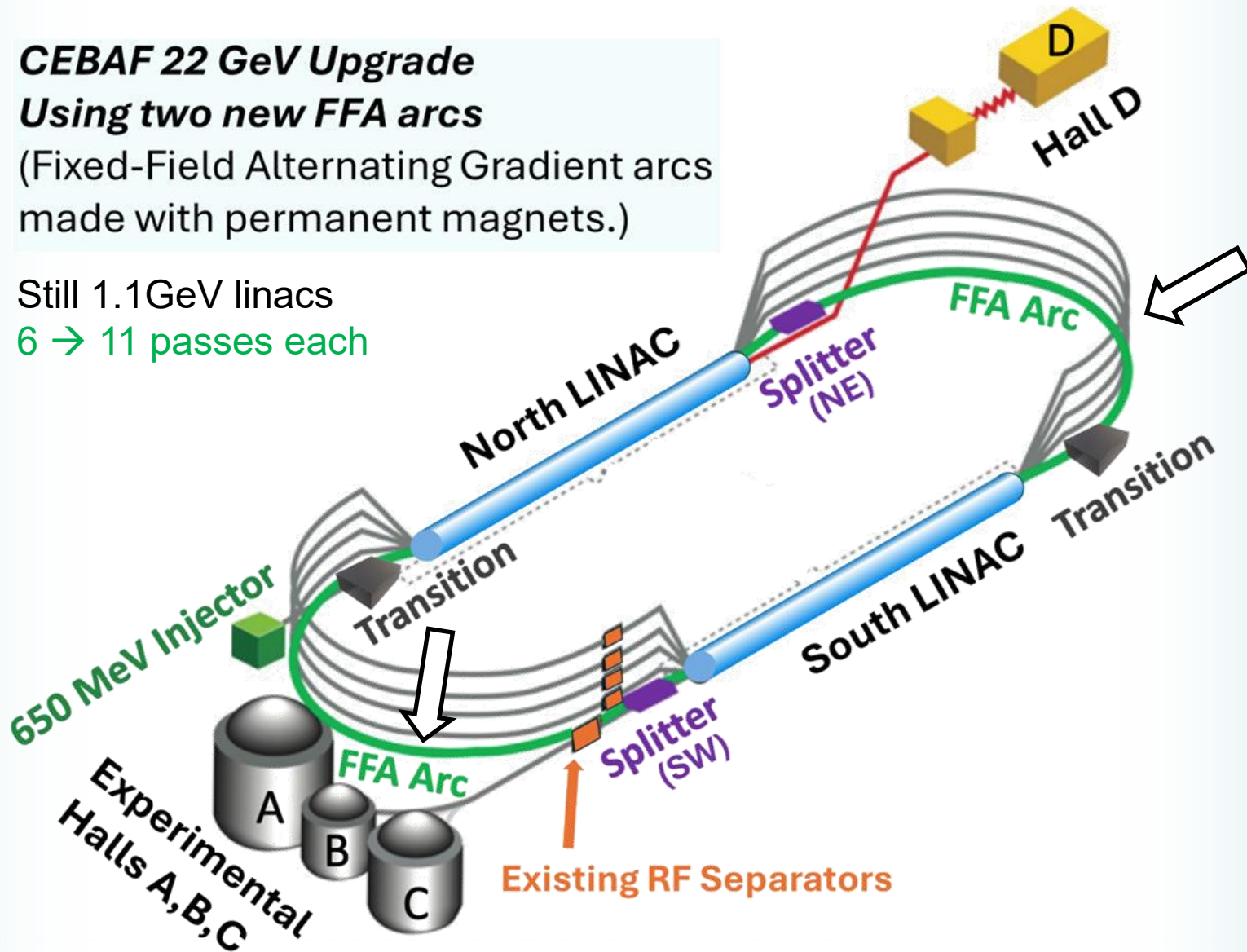

The New FFA Arcs

- A fixed field accelerator (FFA) is a low-dispersion line that can transmit a wide range of energies **simultaneously** (CEBAF is CW)
- The lattice will hold six energies:
 - East arc 10.5-21GeV
 - West arc 11.5-22GeV
- ...while bending around the same average radius of curvature as the existing arcs

FFA Arc Lattice Cell

0.116m length drifts



1.245m length
-0.383T dipole +
43.44T/m gradient

1.673m length
-1.282T dipole +
-41.13T/m gradient

3.150m total length
2.24° total angle
(80.4 per 180° arc)

80.6m bend radius
= CEBAF tunnel



Orbits to scale

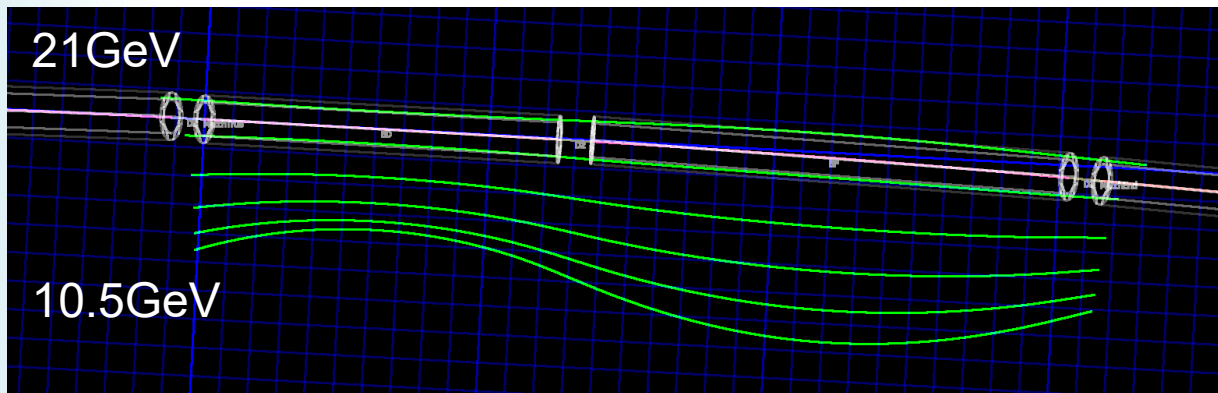

Transversely
exaggerated 16×

Arc Cell Optics and Tunes

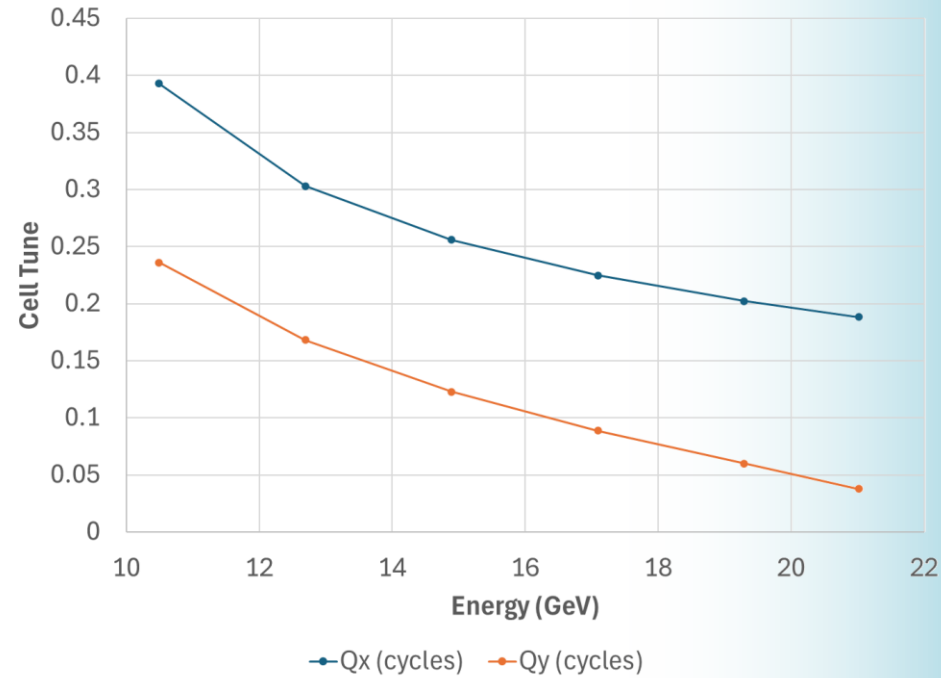
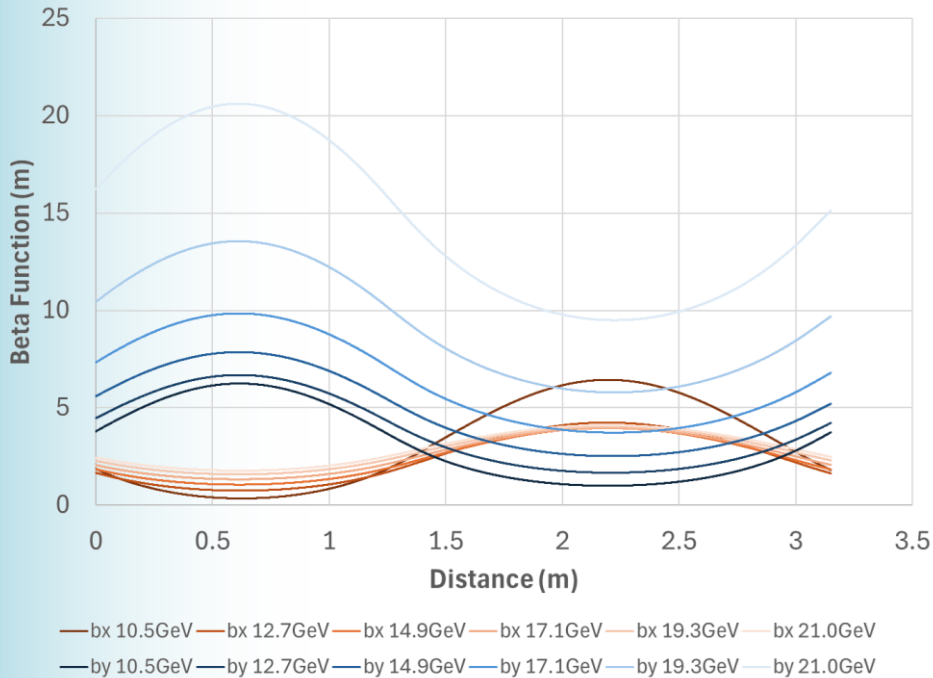

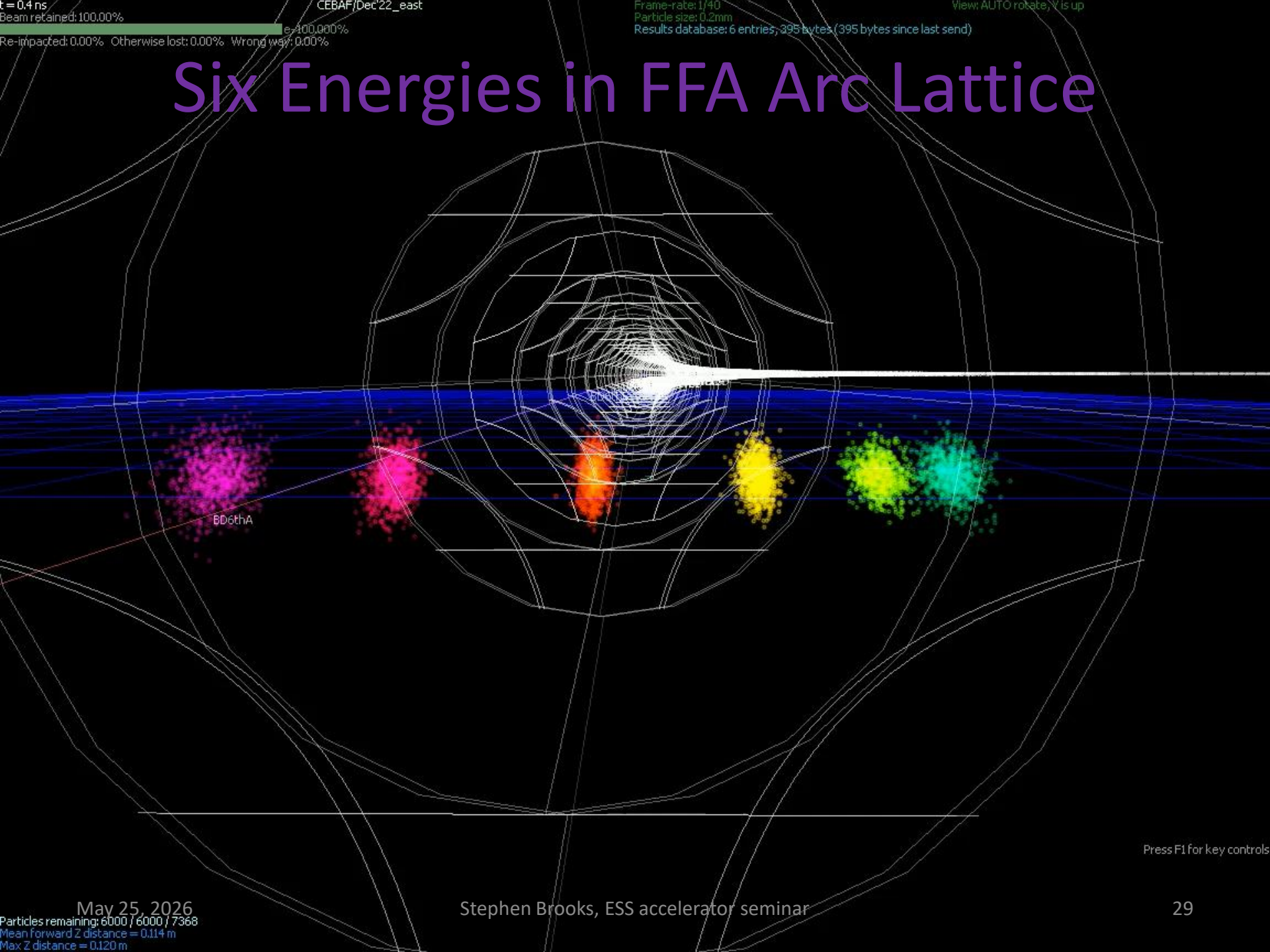

t = 0,4 ns

Beam retained: 100.00%
e- 100.000%
Re-impacted: 0.00% Otherwise lost: 0.00% Wrong way: 0.00%

CEBAF/Dec 22 _east

Frame-rate: 1/40
Particle size: 0.2mm
Results database: 6 entries, 395 bytes (395 bytes since last send)

View: AUTO rotate, Y is up

Six Energies in FFA Arc Lattice

BD6thA

May 25, 2026
Particles remaining: 6000 / 6000 / 7368
Mean forward Z distance = 0.114 m
Max Z distance = 0.120 m

Stephen Brooks, ESS accelerator seminar

Press F1 for key controls

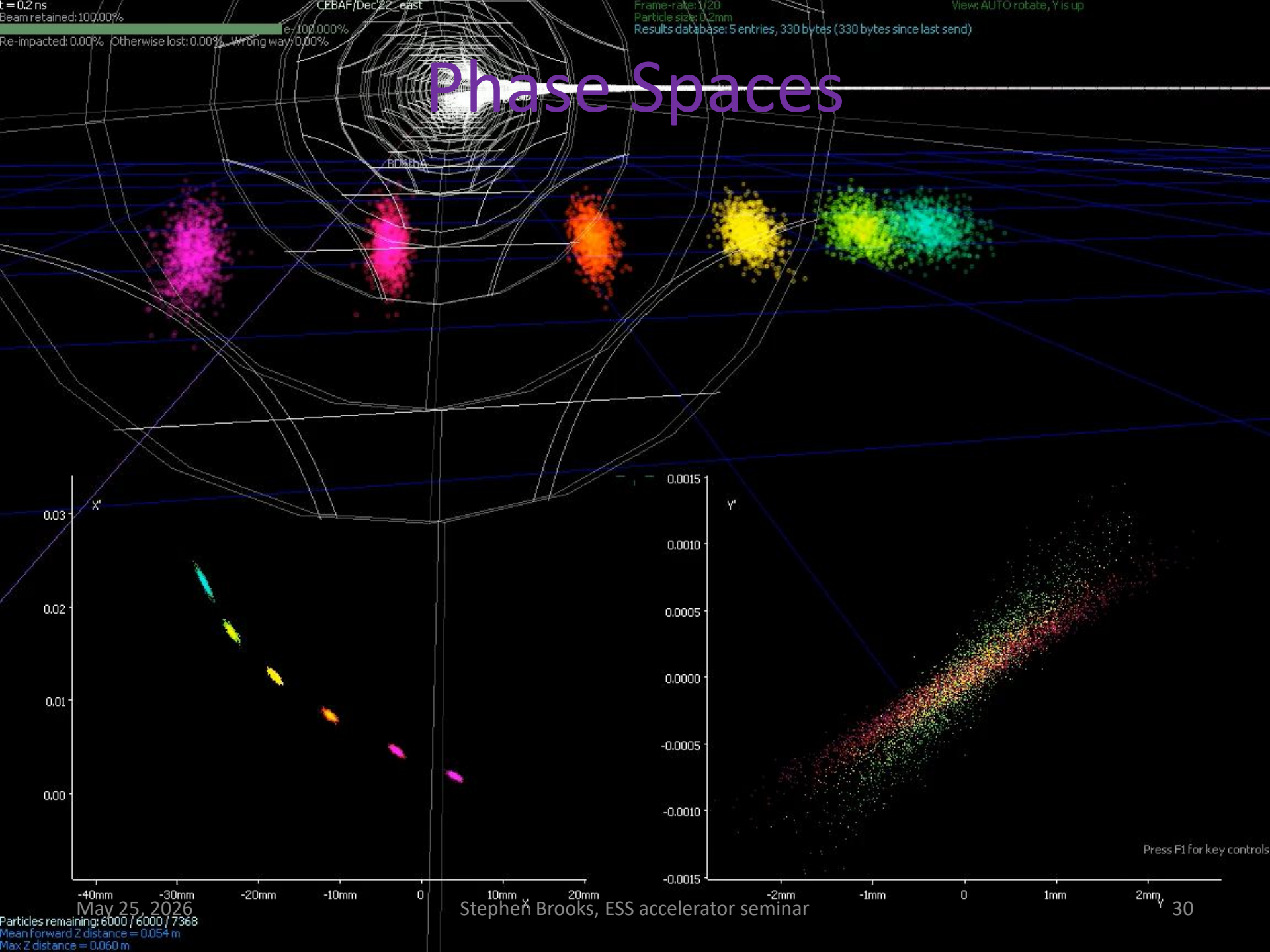

t = 0.2 ns

Beam retained: 100.00%

CEBAF/Dec 22 east

Frame-rate: 1/20

Particle size: 0.2mm

Results database: 5 entries, 330 bytes (330 bytes since last send)

View: AUTO rotate, Y is up

Phase Spaces

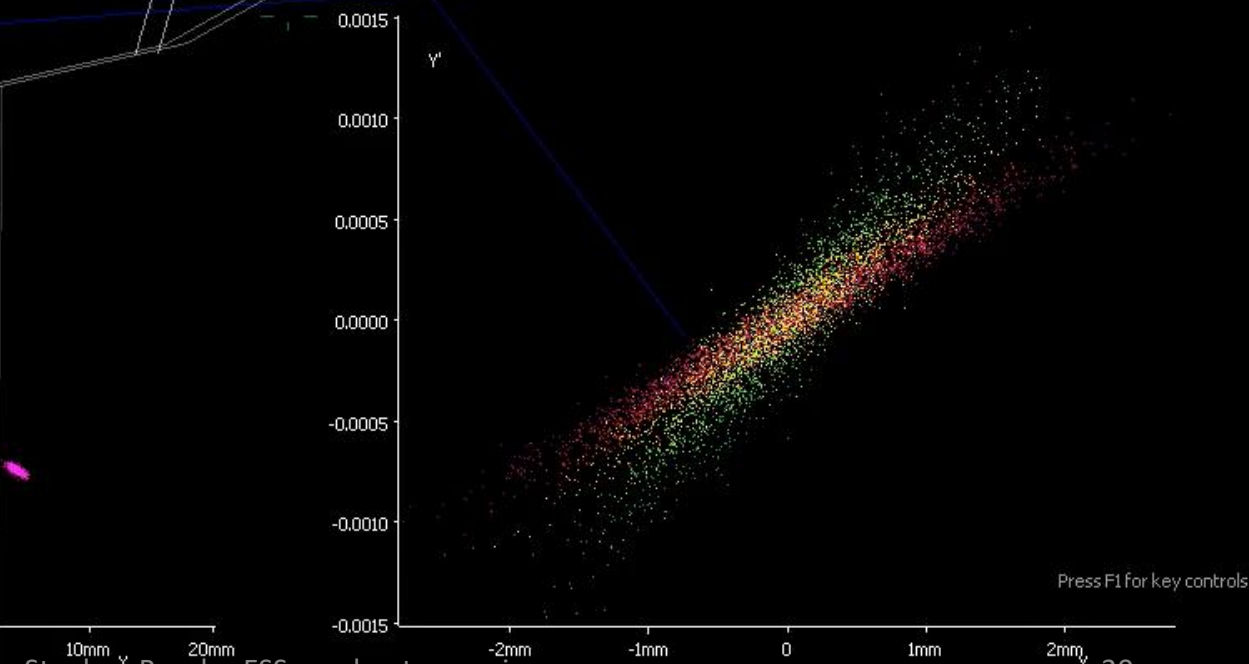
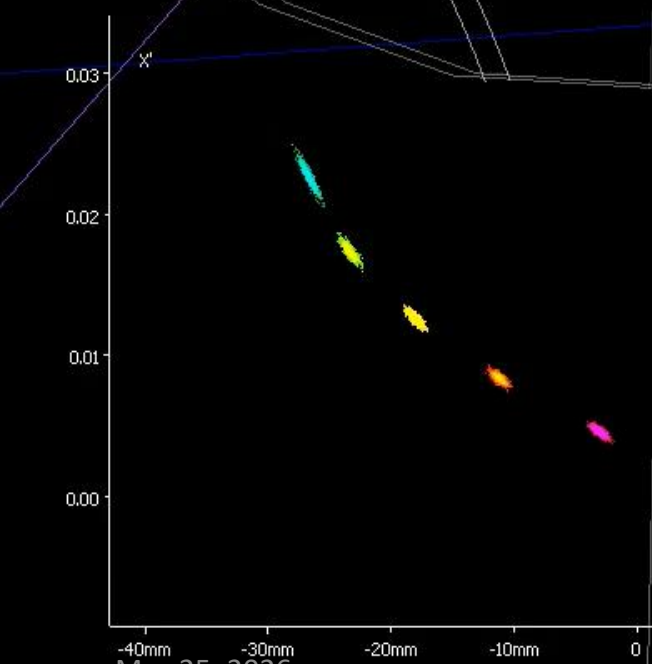
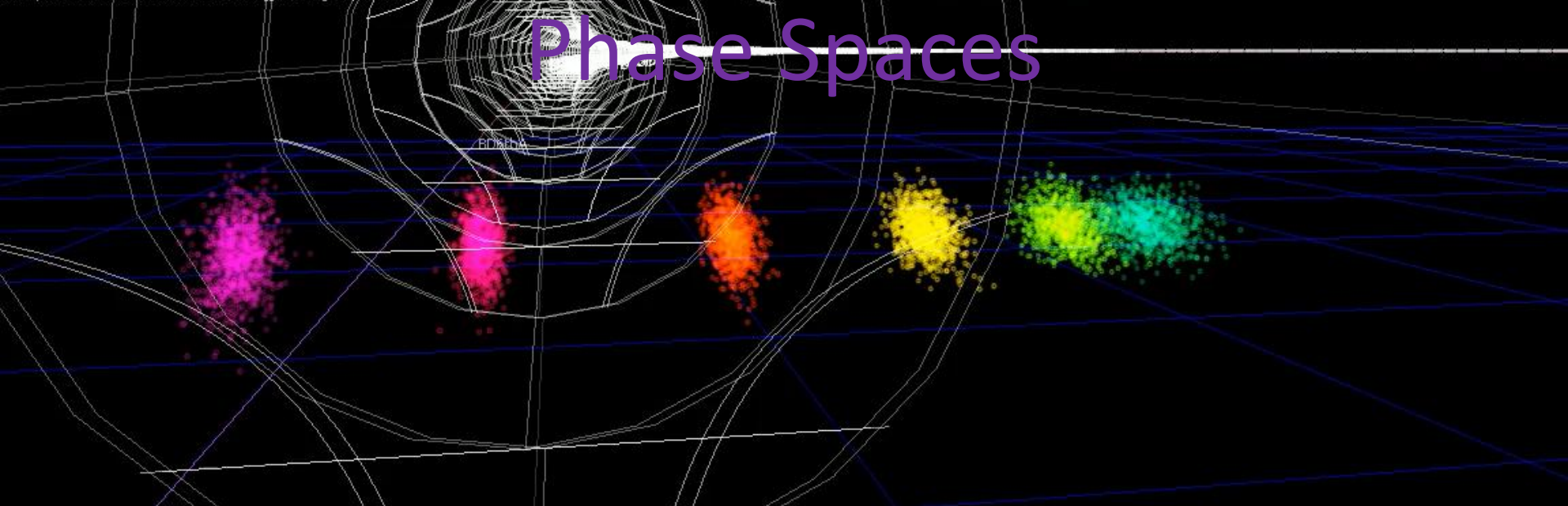

May 25, 2026
Particles remaining: 6000 / 6000 / 7368
Mean forward Z distance = 0.054 m
Max Z distance = 0.060 m

Stephen Brooks, ESS accelerator seminar

Press F1 for key controls

High-Field Combined Function Permanent Magnet

- We prototyped an open midplane design with the following requirements:
 - -0.9512T central field + 55.54T/m gradient
 - $\pm 10.5\text{mm}$ good field region
 - $B_{\text{max,gfr}} = -1.536\text{T}$
 - $\pm 7.5\text{mm}$ vertical aperture
 - 6mm total side gap for SR
 - 10^{-3} field accuracy
- Similar to CEBAF upgrade

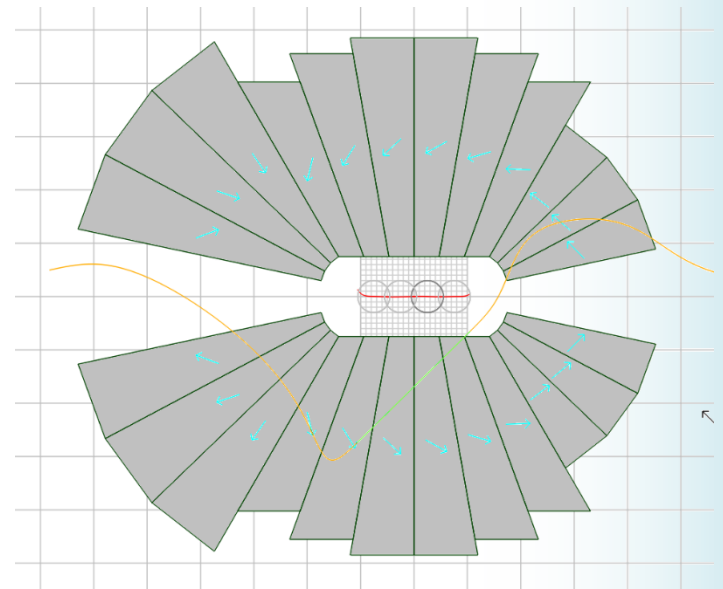

Tooling Design

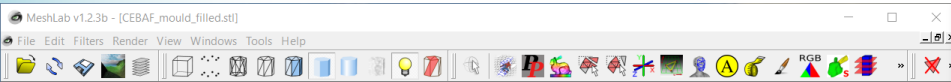

Full mould
all pieces and central plug, printed
double wall thickness for strength

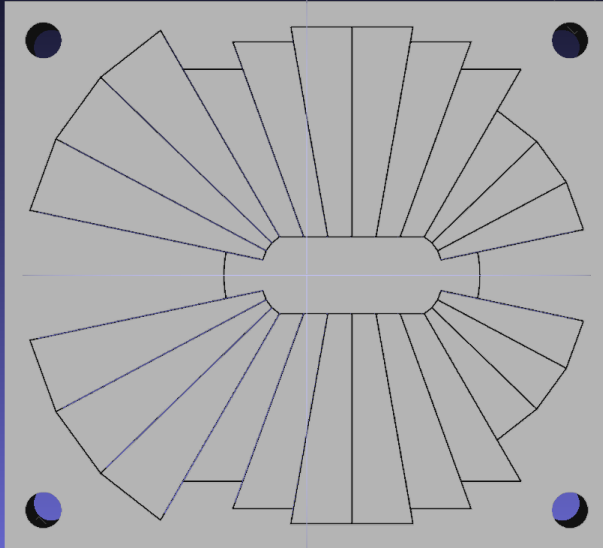

“Spider”
Channels for half the pieces
Can be flipped over to get other half

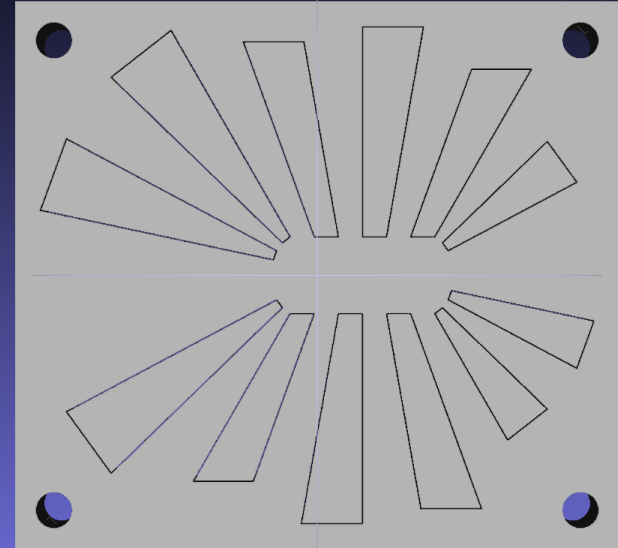

Corner holes for $\frac{1}{4}$ ”-20 threaded rods throughout, provide loose alignment, constraint

LOG MESSAGES Vertices: 1116584 Faces: 2233084 FOV: 60 FPS: 5.5

LOG MESSAGES Vertices: 1030180 Faces: 3437892 FOV: 60 FPS: 3.3

Can 3D print all parts in place

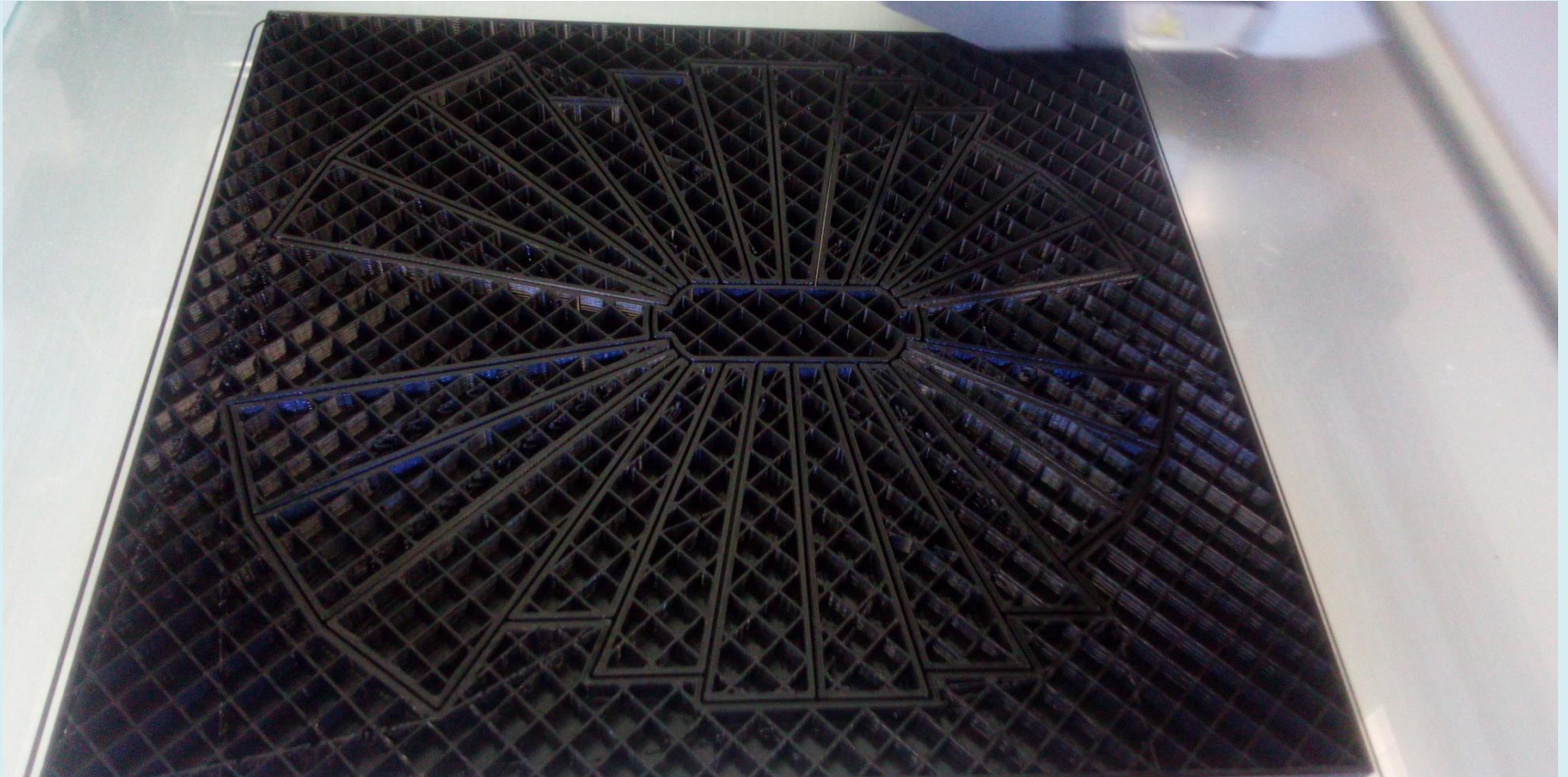

0.3mm spacing between pieces minimum possible with our printers

Point field measurement tool for Hall probe, also a “spider”

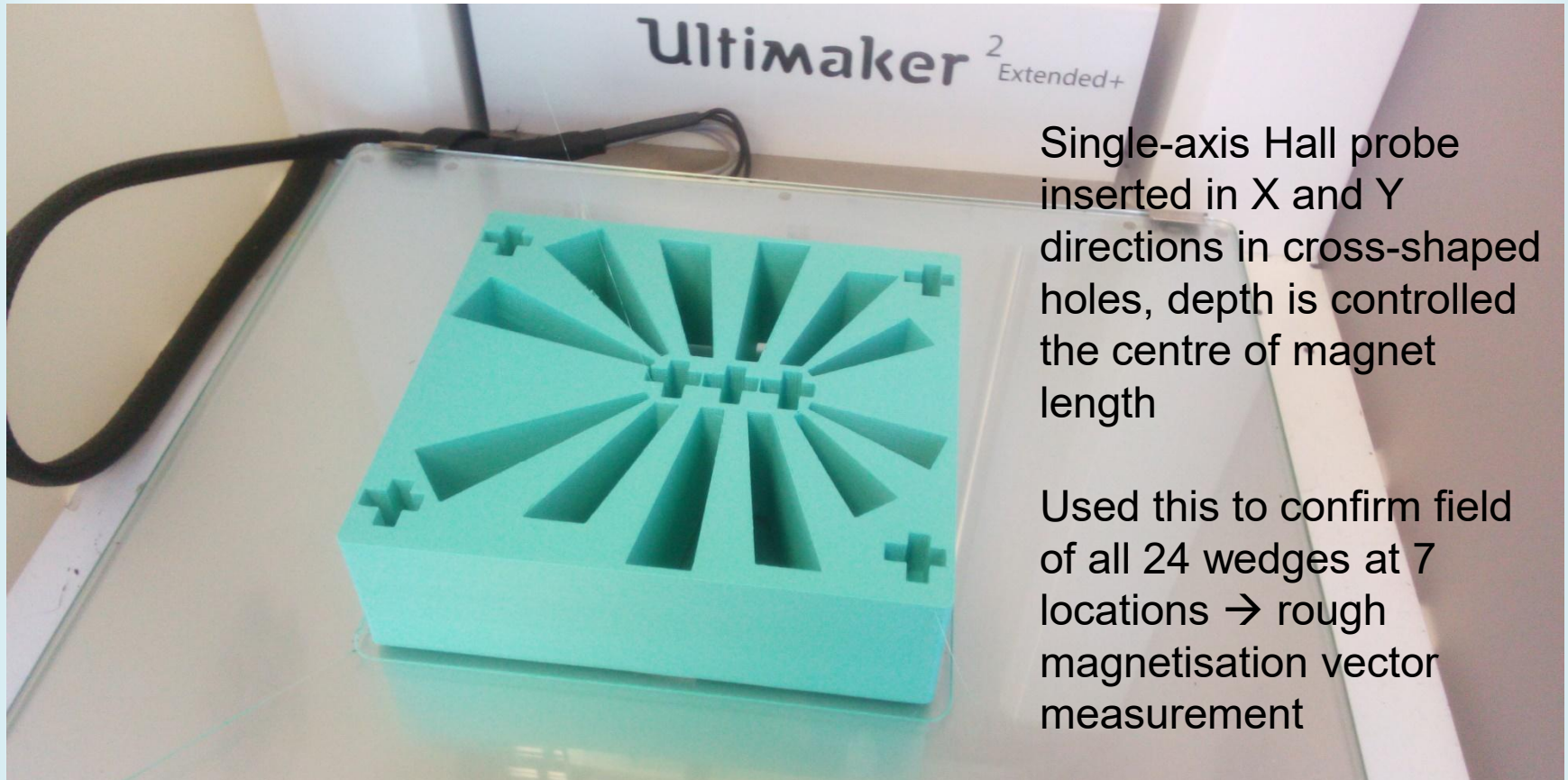

Single-axis Hall probe inserted in X and Y directions in cross-shaped holes, depth is controlled the centre of magnet length

Used this to confirm field of all 24 wedges at 7 locations → rough magnetisation vector measurement

Assembly Sandwich

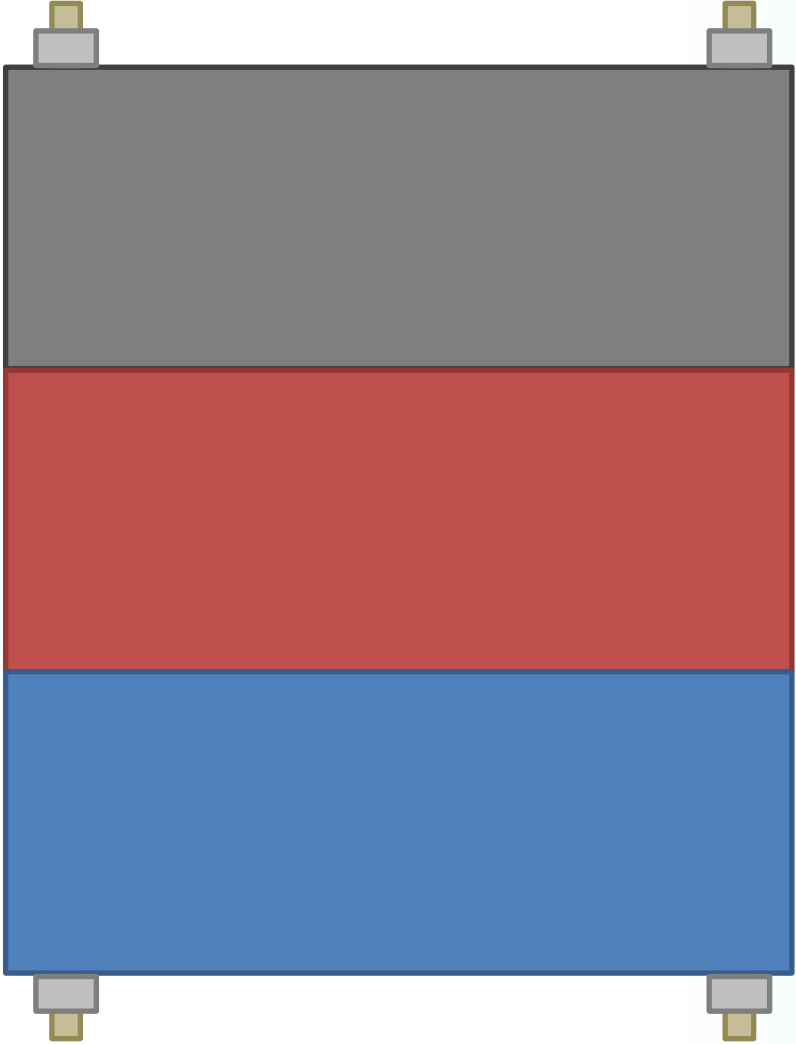
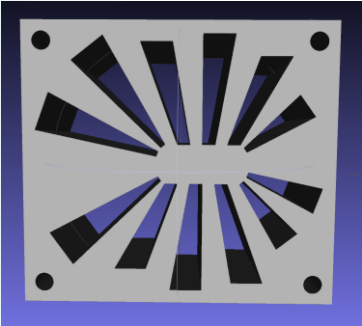
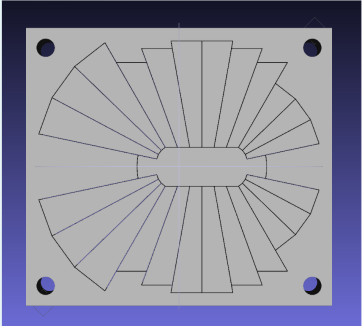
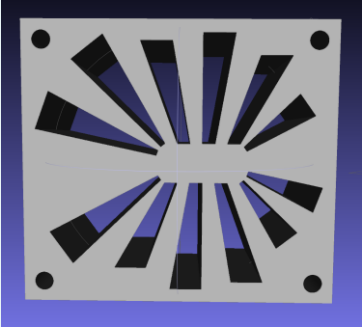

Assembly Process

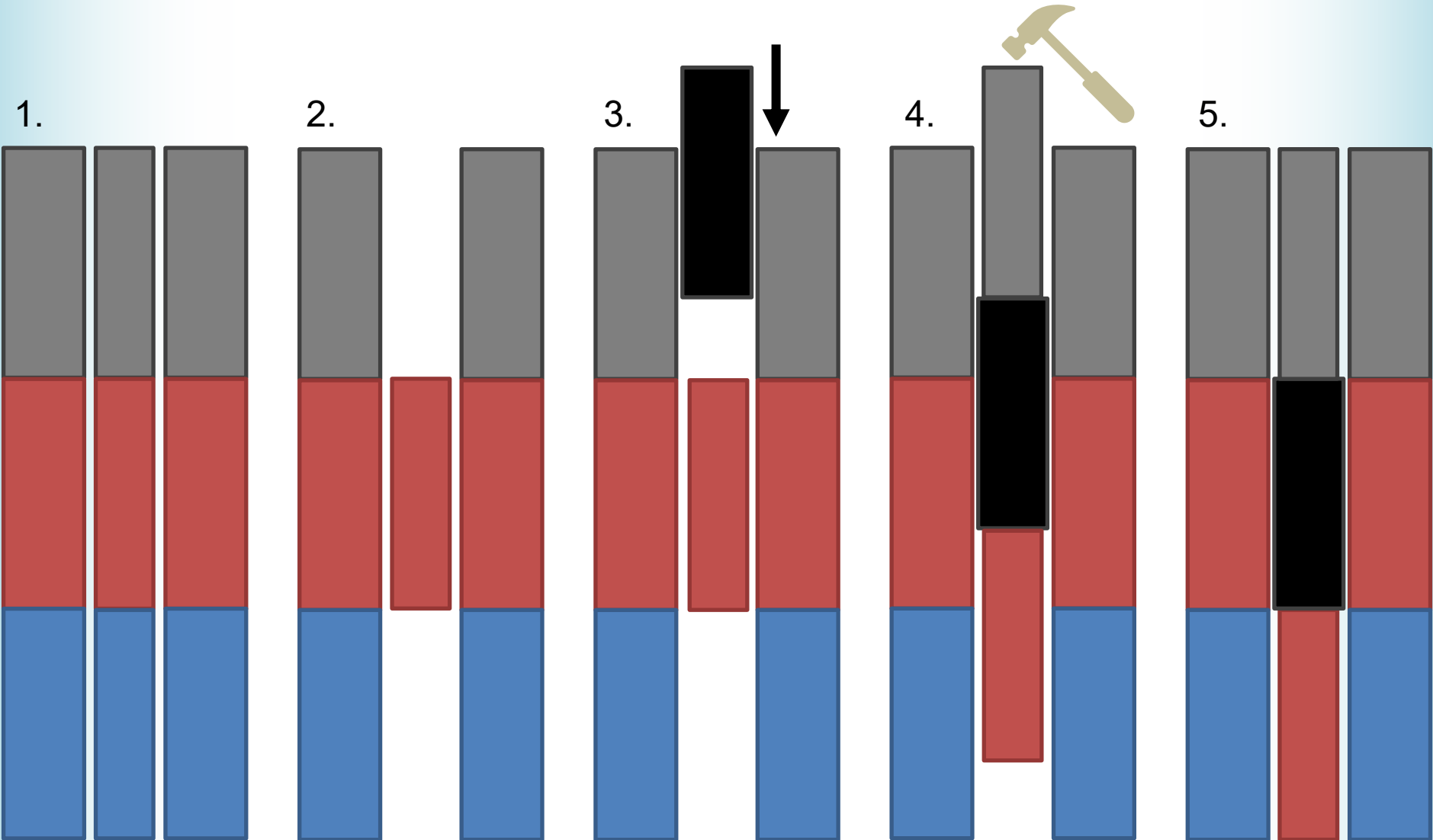

Half Assembled (Metal Frame)

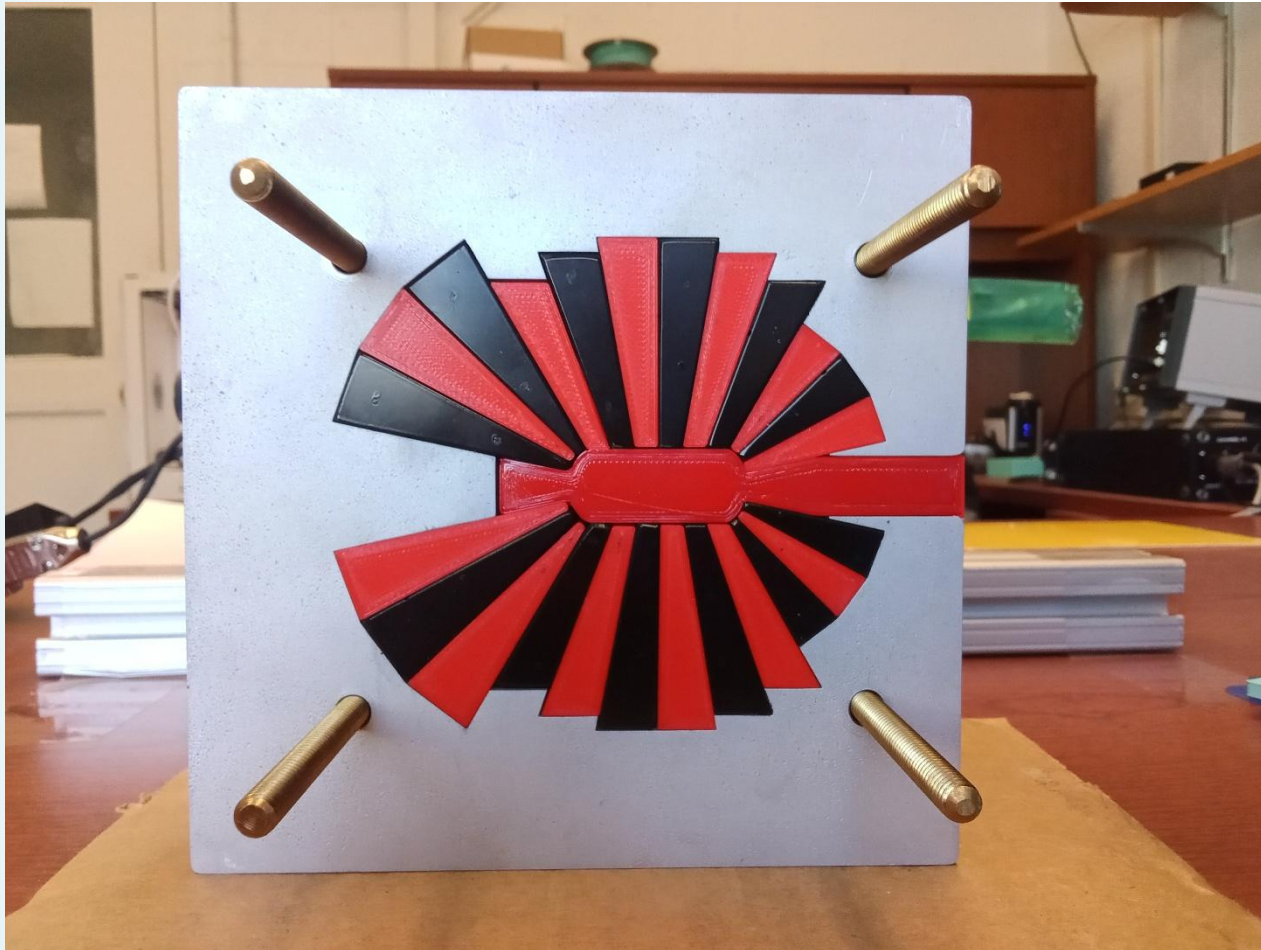

Bought sets of 24 permanent magnet wedges from AllStar Magnetics

- Material grade N42EH
- $B_r=1.30T$
- 45mm length

Assembled Magnet (Plastic+Metal)

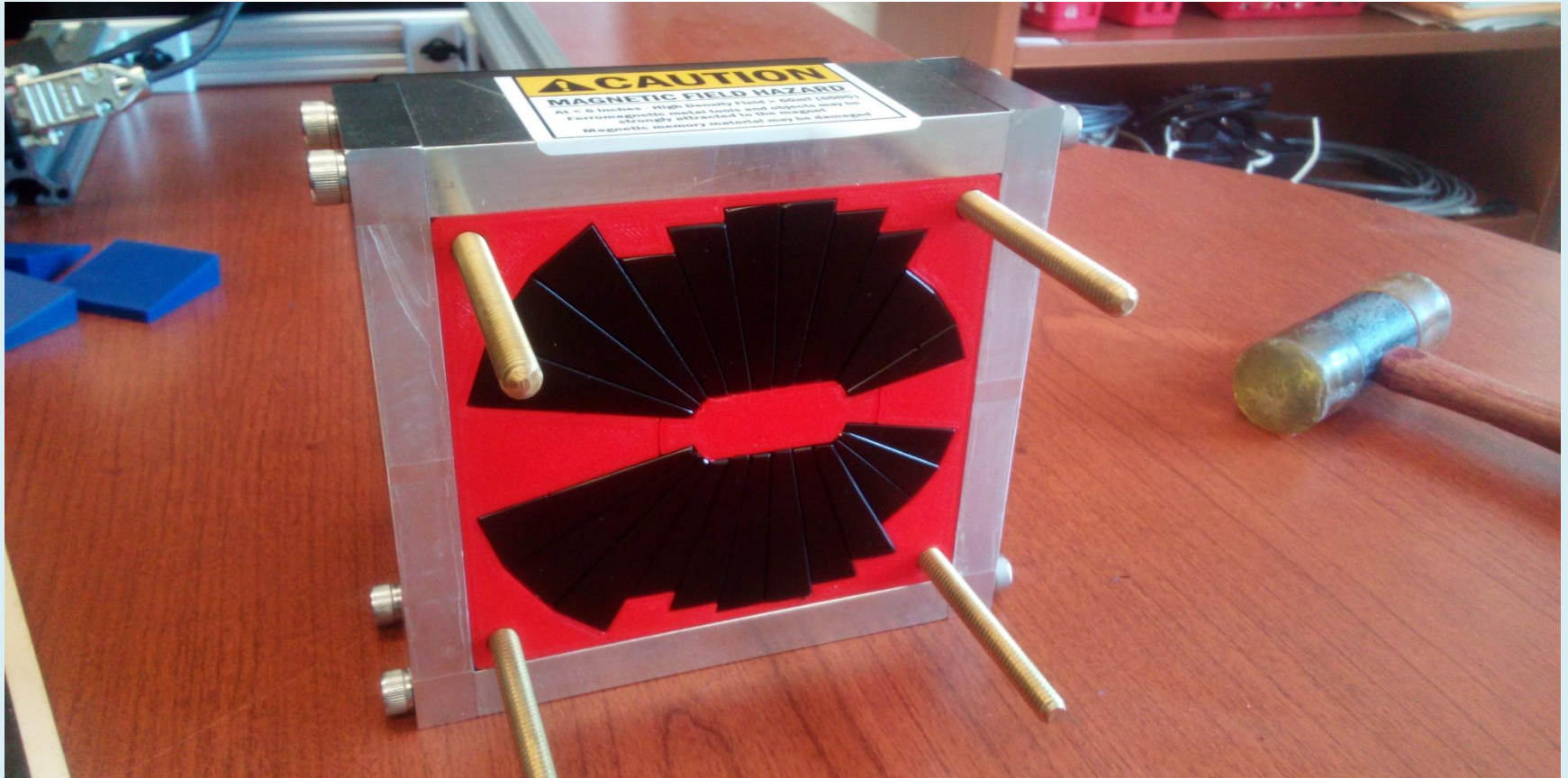

Outer $\frac{1}{2}$ " thick aluminium frame for strength

Assembled Magnet

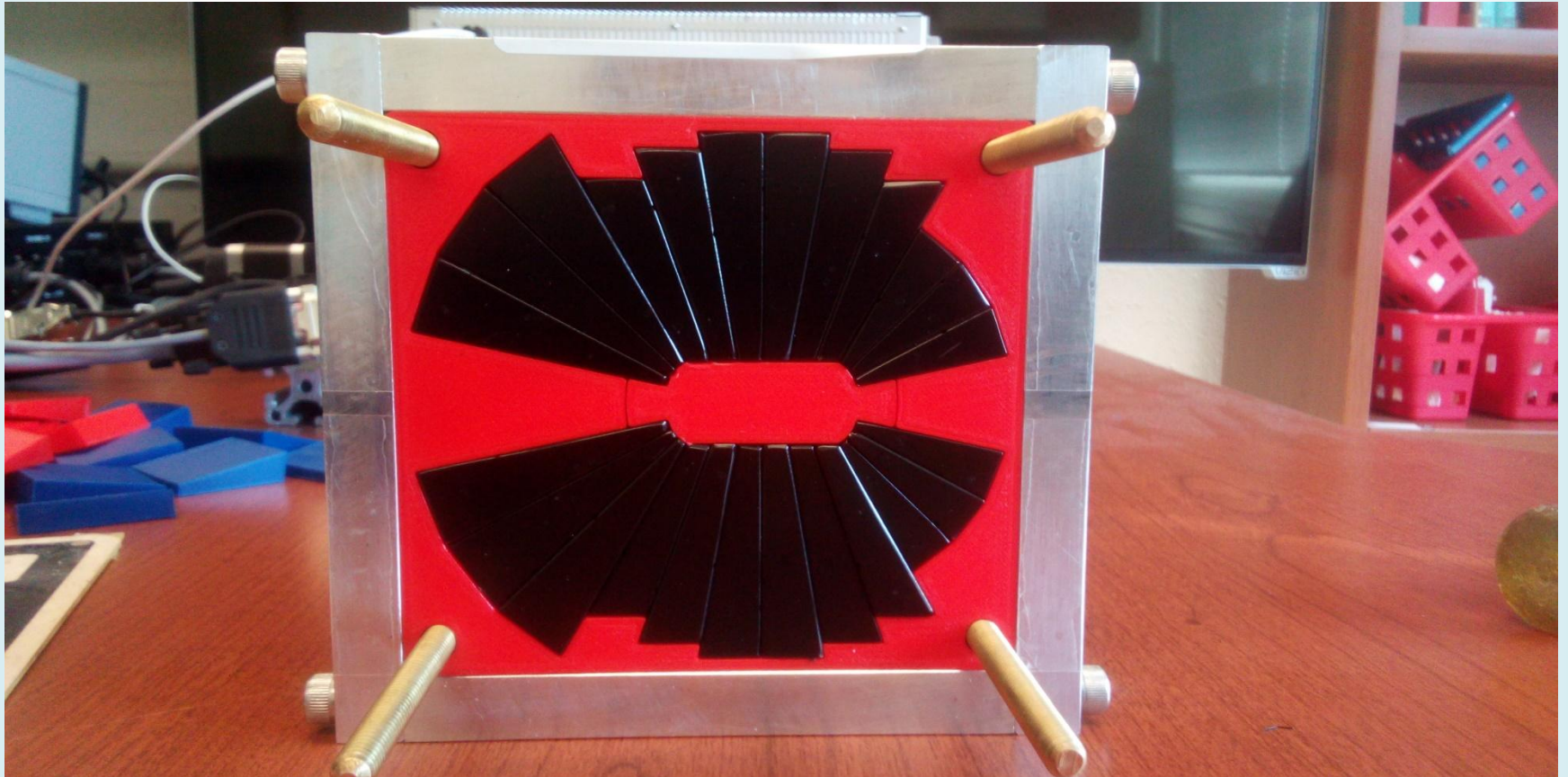

Outer $\frac{1}{2}$ " thick aluminium frame for strength

Endcaps for Safety (no shims here)

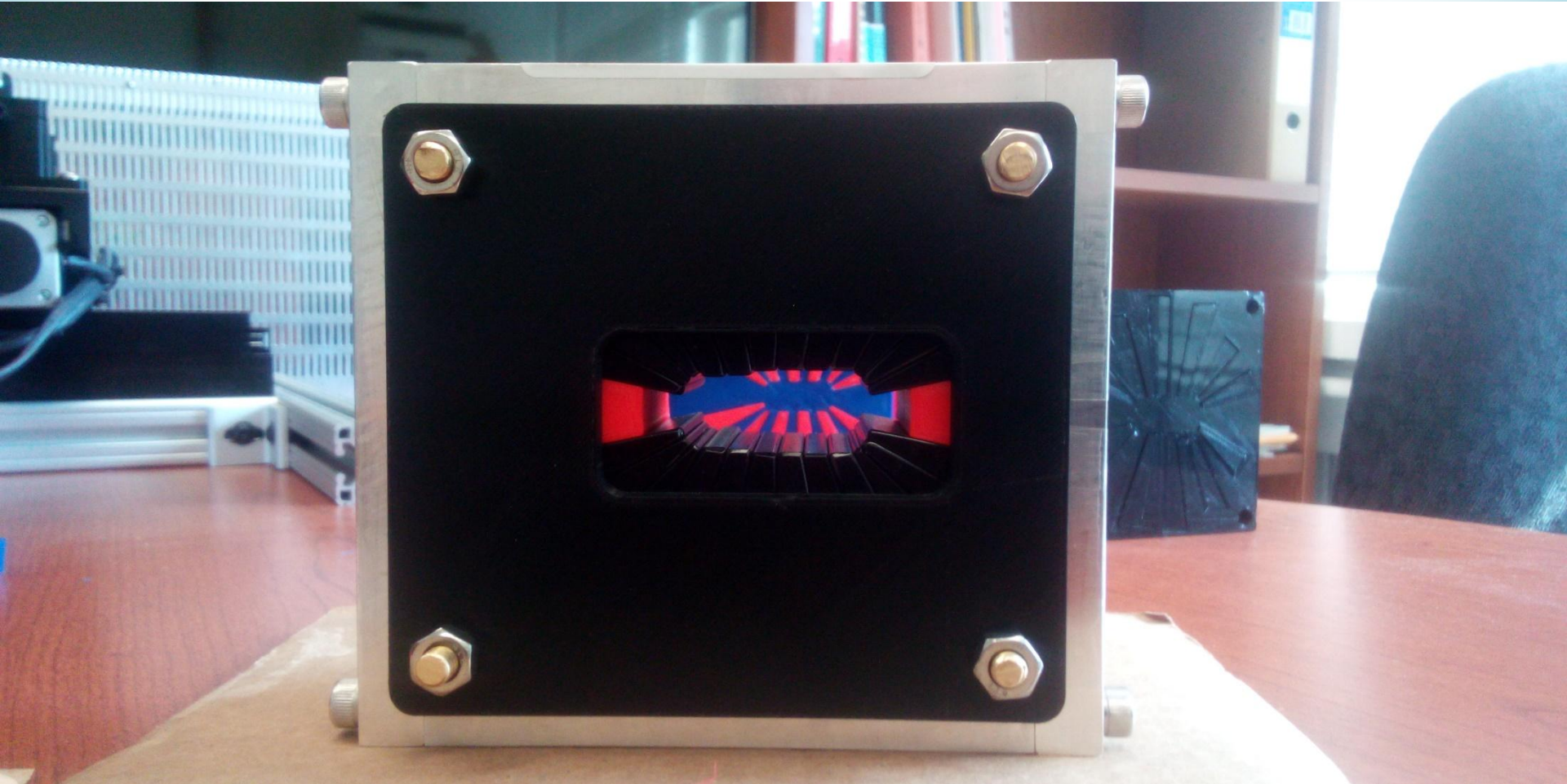

High fields exist in aperture



Fieldmap Measurement

- Used Senis 3MH6 teslameter with 3-axis Hall probe
 - Accurate to $\pm 0.01\%$
- Two (horizontal X,Z) linear movement stages
 - Accurate to 1 μm
- $\pm 10.5\text{mm} \times 200\text{mm}$
 - 0.5mm, 2.5mm steps
- 8 repeated scans



Fieldmap Measurement



Graphical Fieldmap Plot



Aperture after Brass Shims (Run 2)

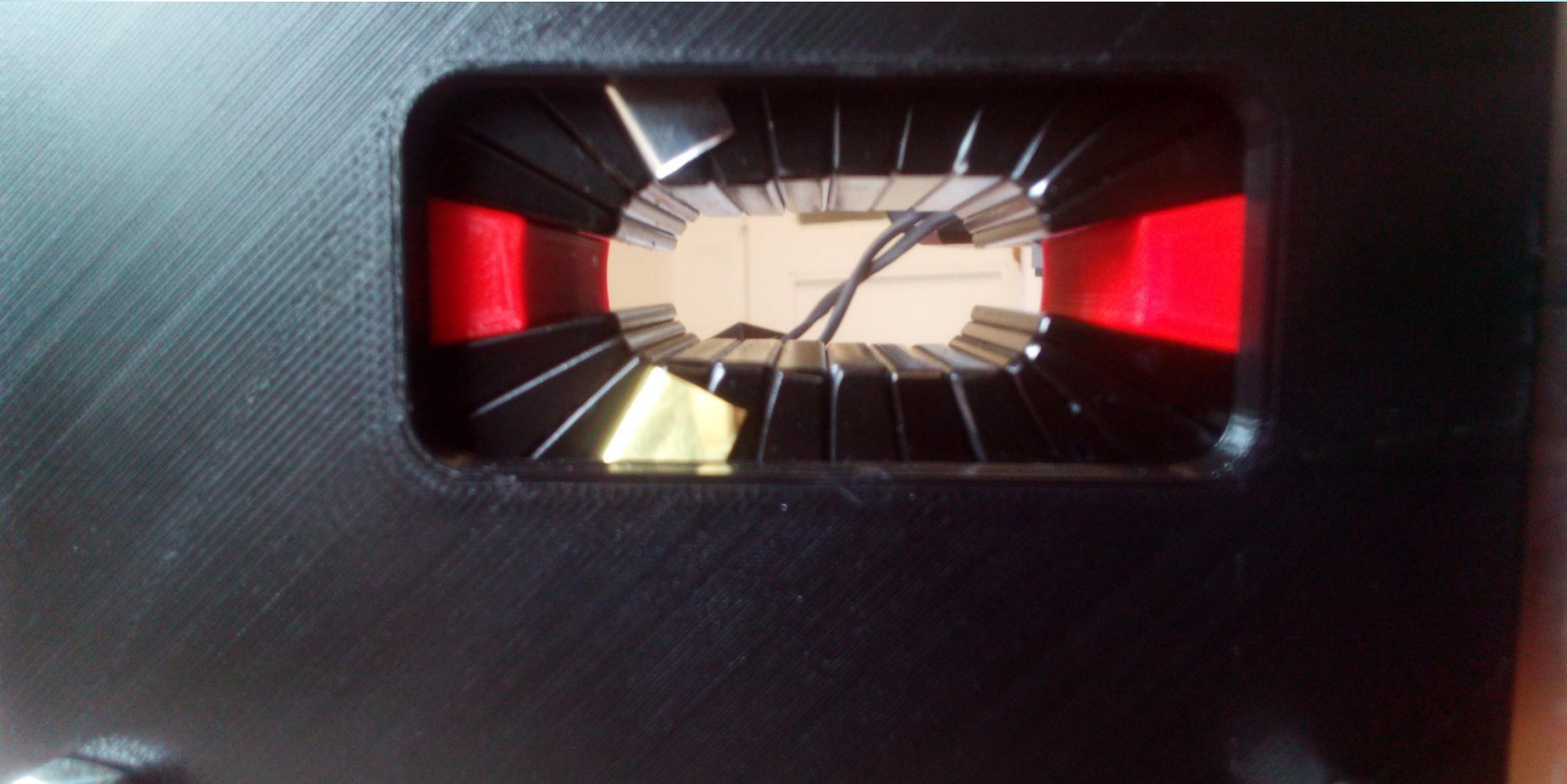

Magnet with Iron Tuning Rods

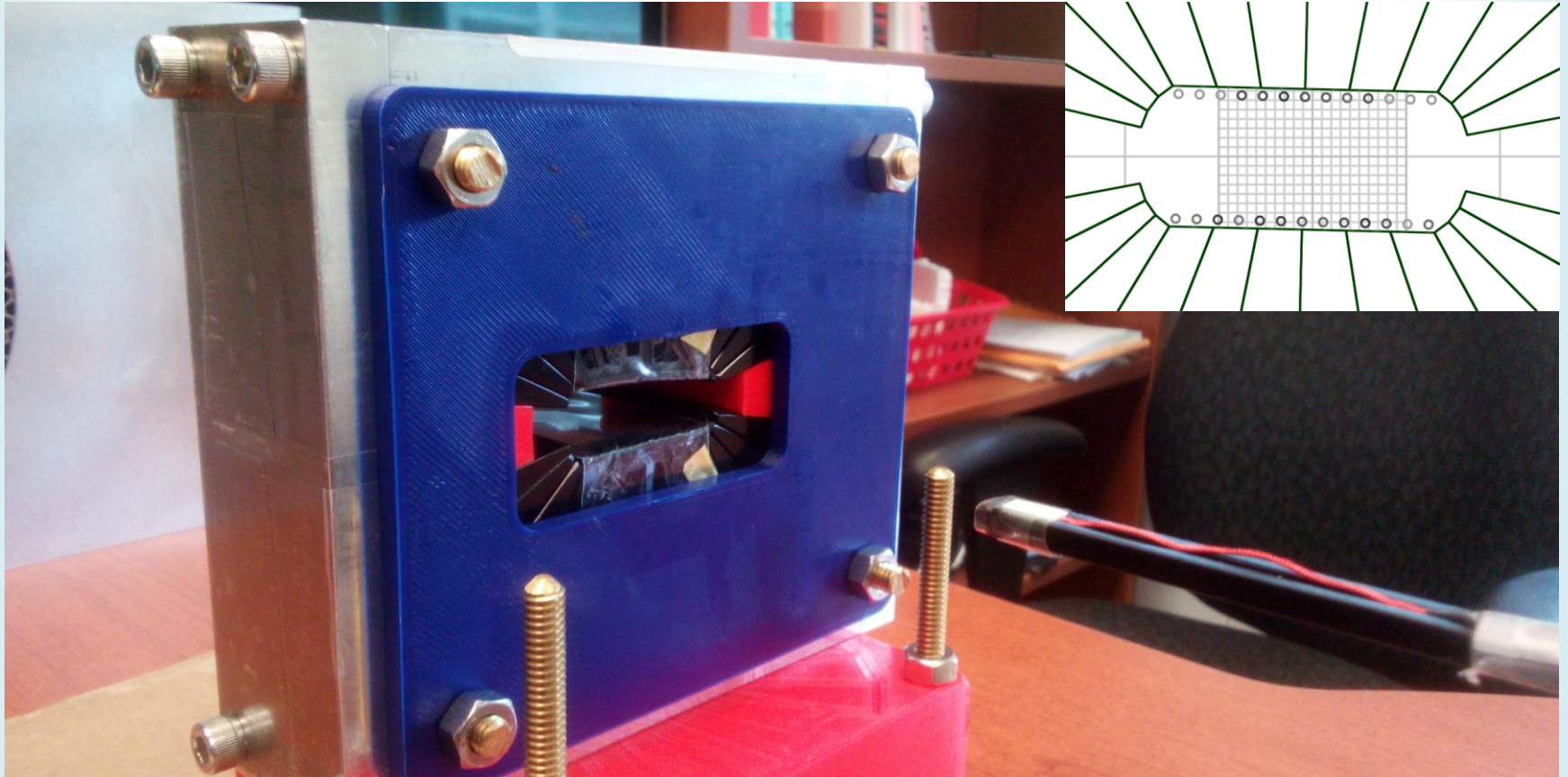

Magnet with Iron Tuning Rods



Maximum Field Error History

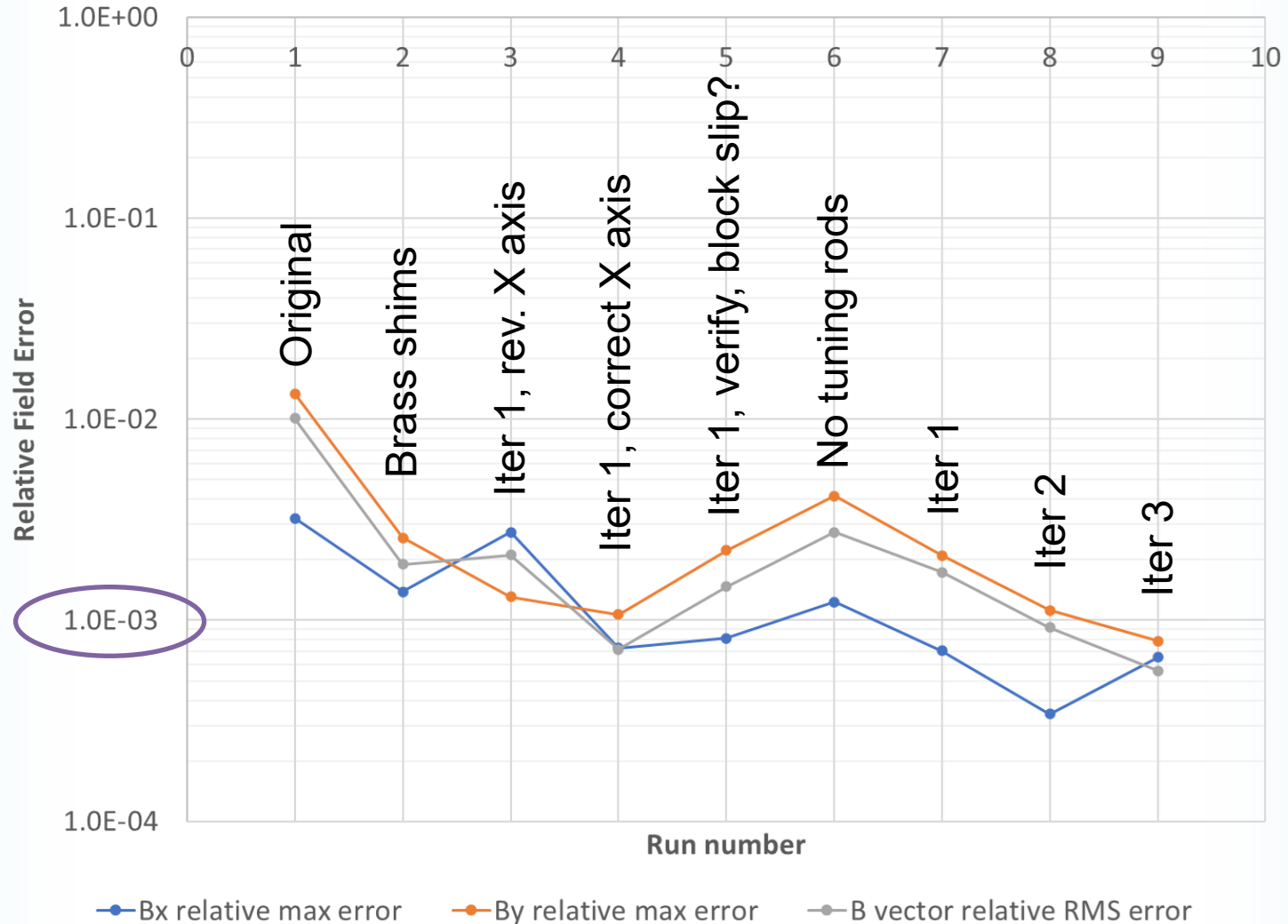

Integrated Fields (Run 9)

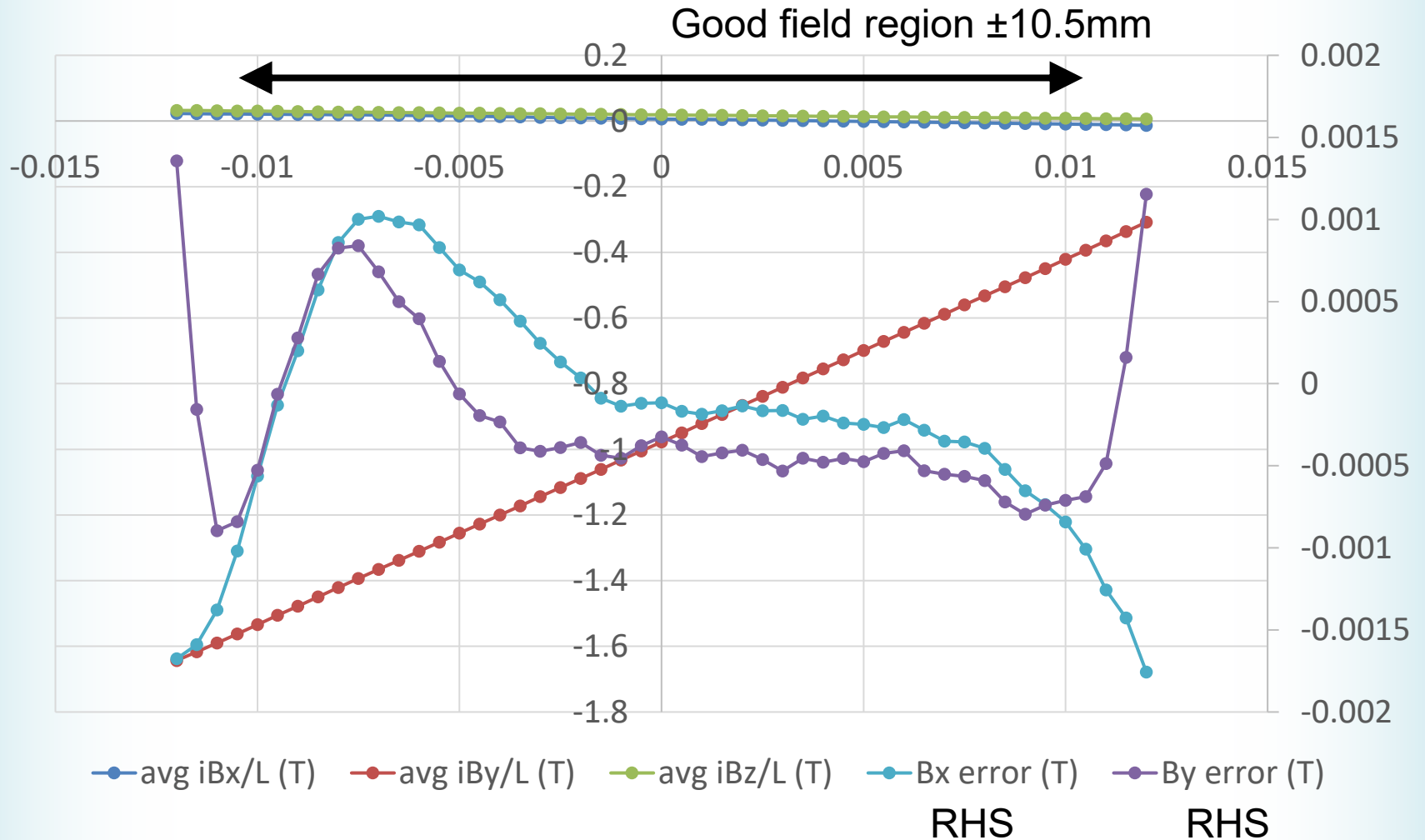

Integrated Field Error History

- Gradual improvement over runs 6-9
- Short magnets often require more iterations because of end field effects

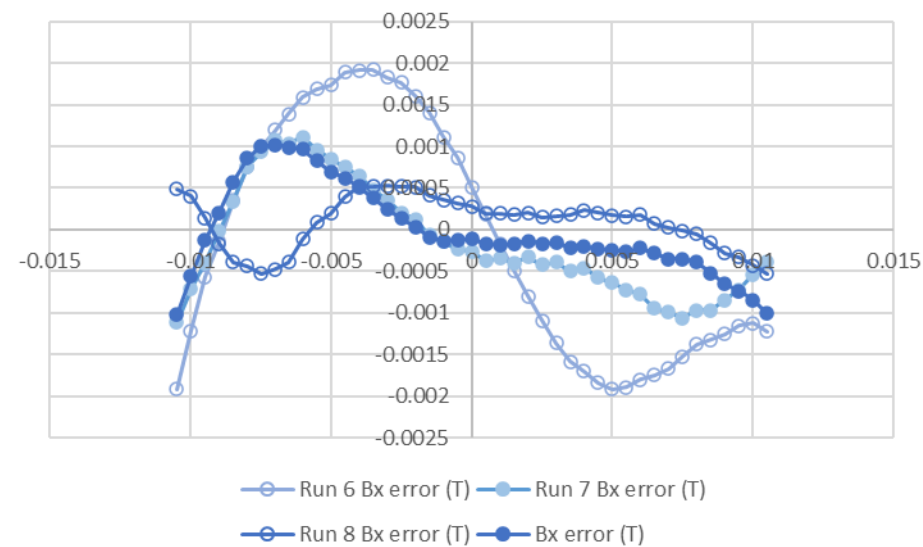
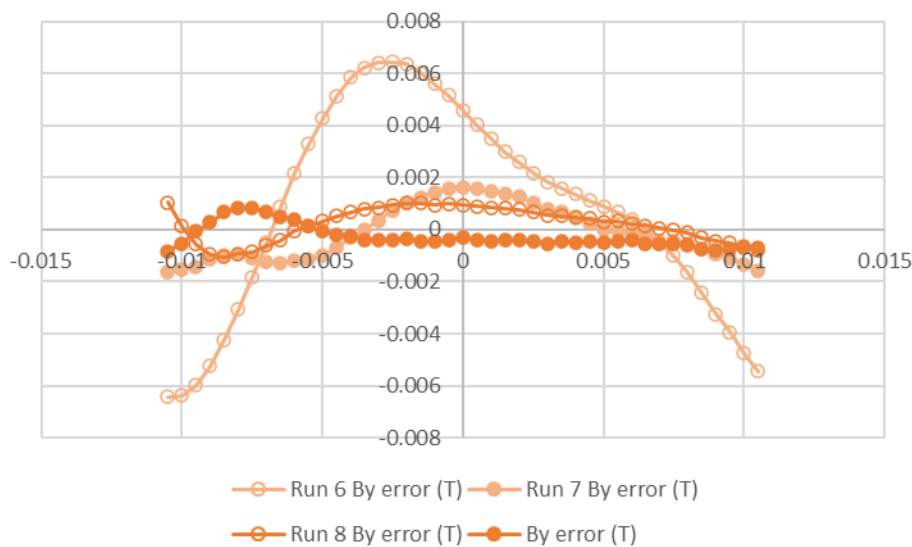

Prototype Magnet Conclusion

- A short section of magnet similar to CEBAF upgrade FFA has been tuned to $<10^{-3}$ accuracy
 - No glue/epoxy was used (might reuse wedges), so some issues with blocks staying in place
- Temperature variation and material thermal coefficient appears to be the main source of measurement error now
 - Working on temperature-controlled enclosure

Similar Permanent Magnets Built in Industry and Tested with Beam

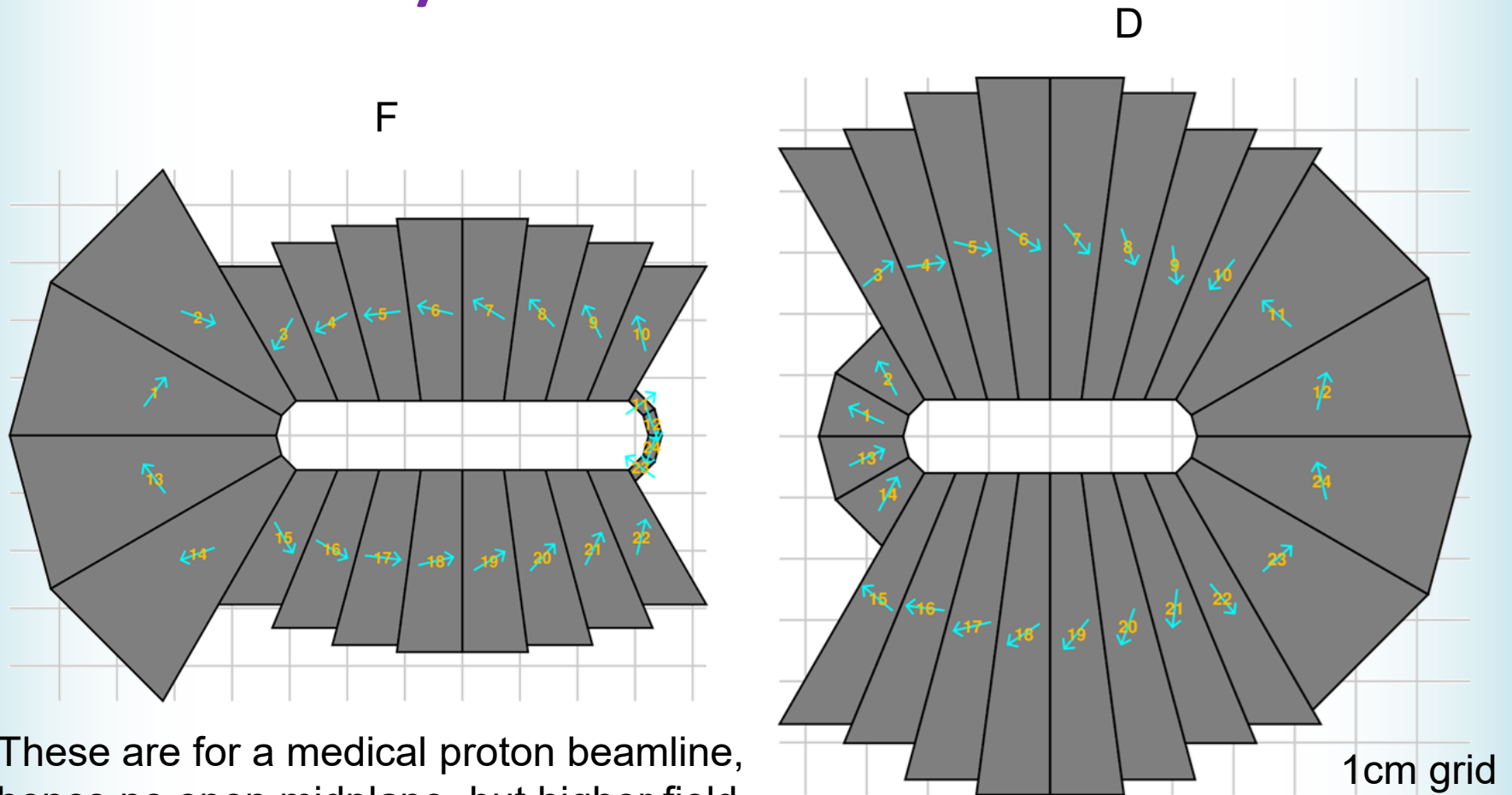

These are for a medical proton beamline, hence no open midplane, but higher field (1.85T), similar in width to CEBAF magnet

Test Beamline Magnet Parameters

Parameter	F magnet	D magnet	Unit
Material	NdFeB		
Grade	N42EH		
Remnant field B_r	1.30		T
Area	69.90	93.88	cm ²
Full aperture	64.7 × 12	48.1 × 12	mm
Good field region x	±26.3	±18.0	mm
Maximum field	1.85	1.86	T

Nonlinear Magnet Field Profiles

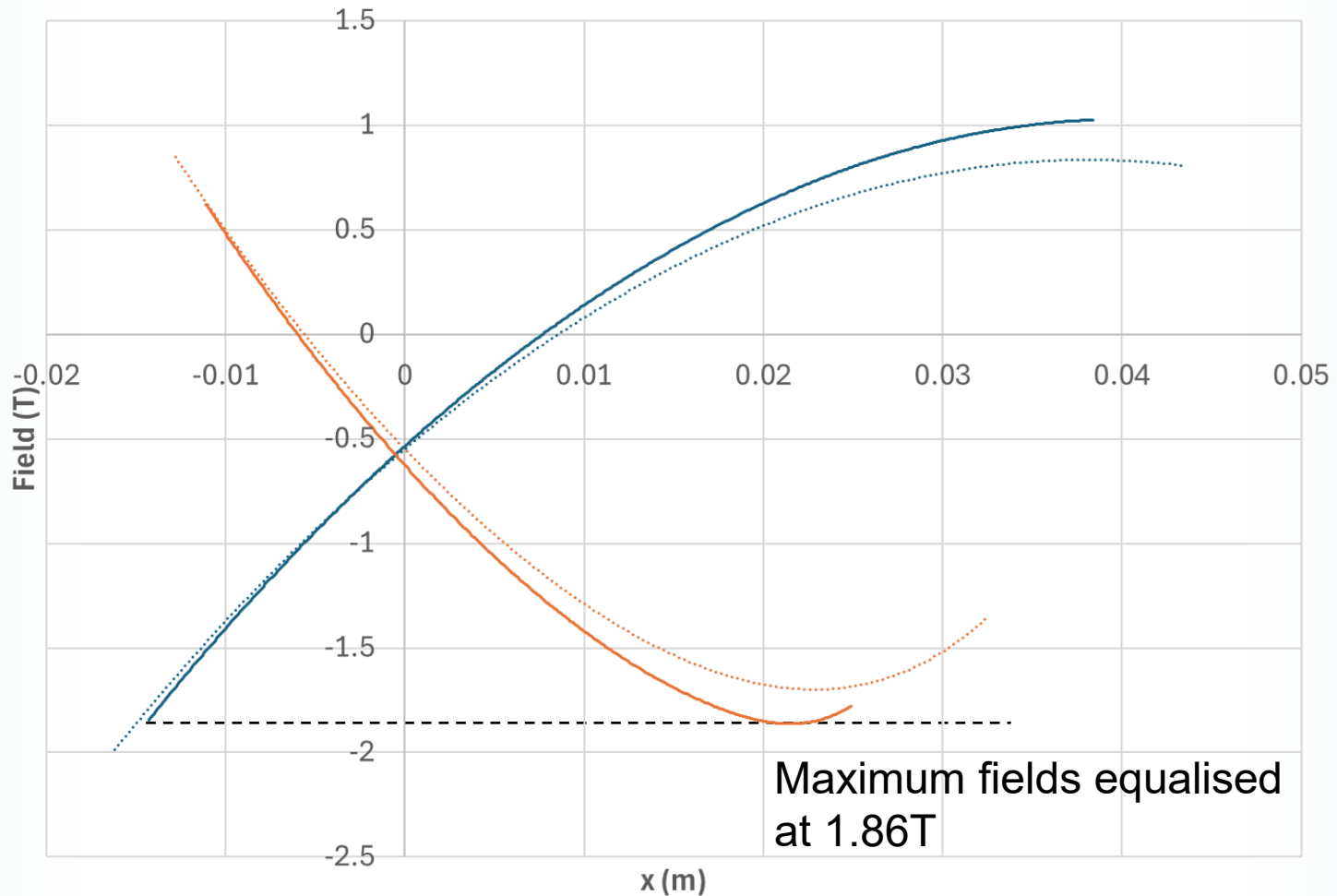

..... F field original (T) D field original (T) — F field (T) — D field (T)

Test Beamline Simulated Orbits

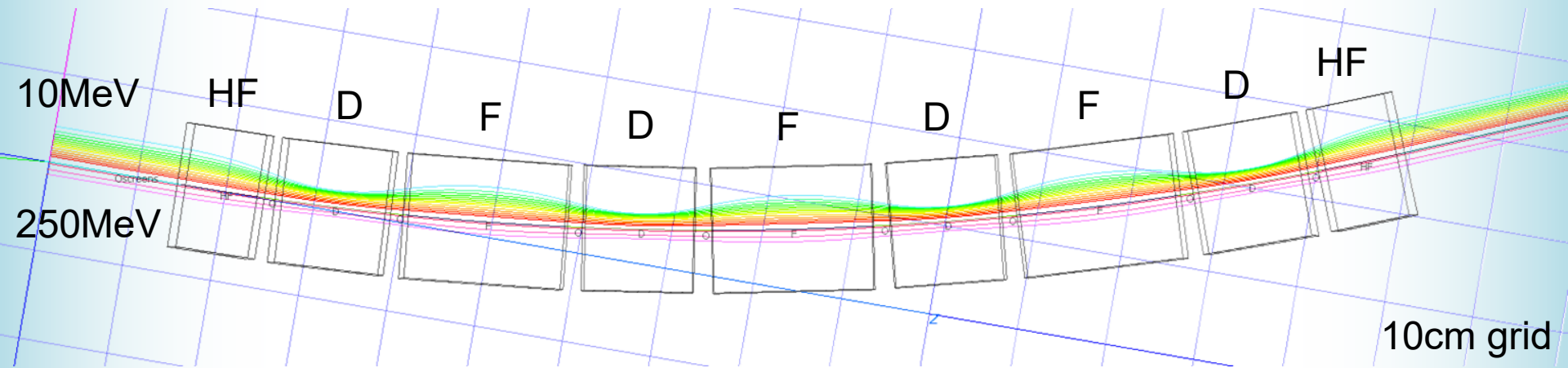

Angle 5.625° per cell, 4 cells total = 22.5° (1/8 of an 180° arc)

Half-F magnets on each end \rightarrow parallel orbits

Cell length 34.4cm, 4 cells total = 1.374m

Lower energy, higher bend angle than CEBAF upgrade

Magnets Ordered from SABR Enterprises, LLC.

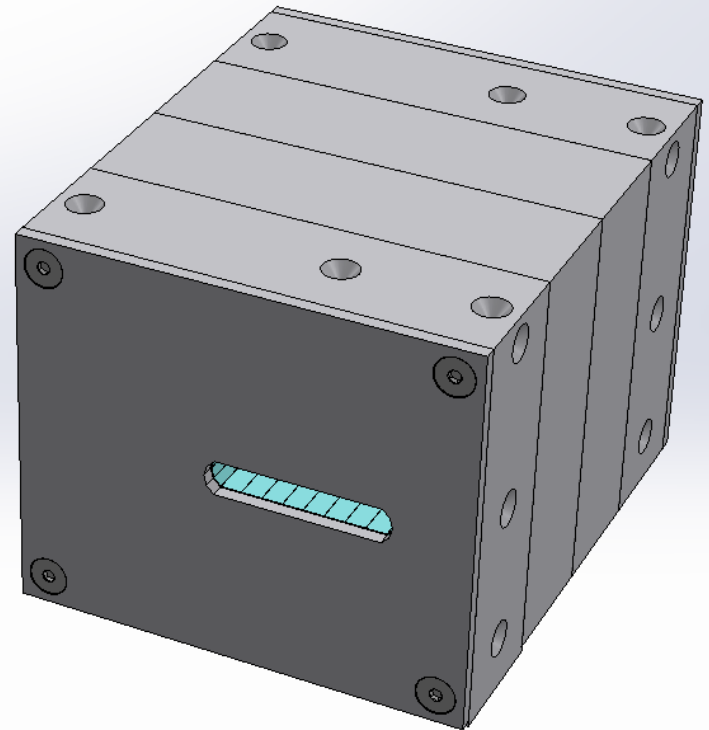
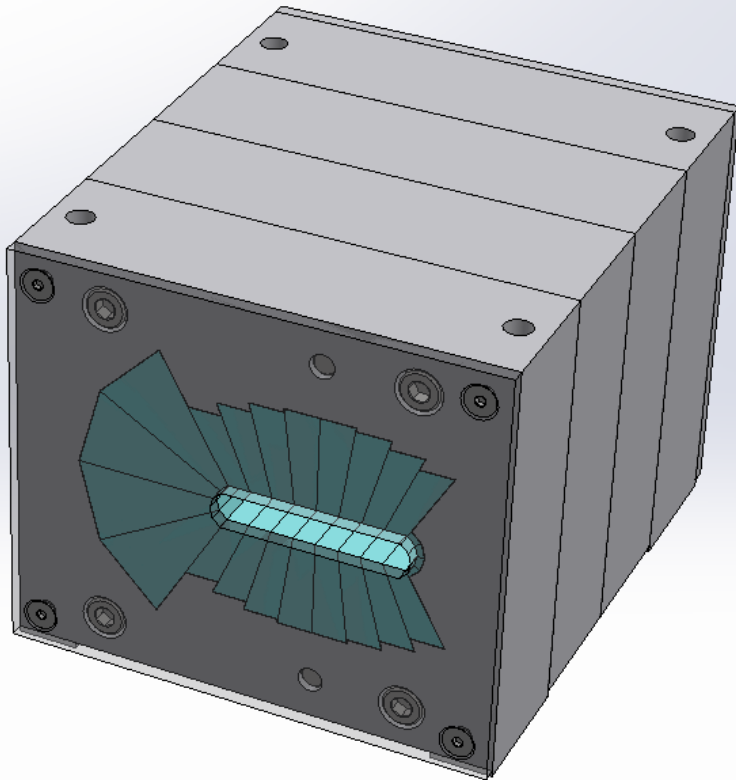

Orbits within Magnet Models

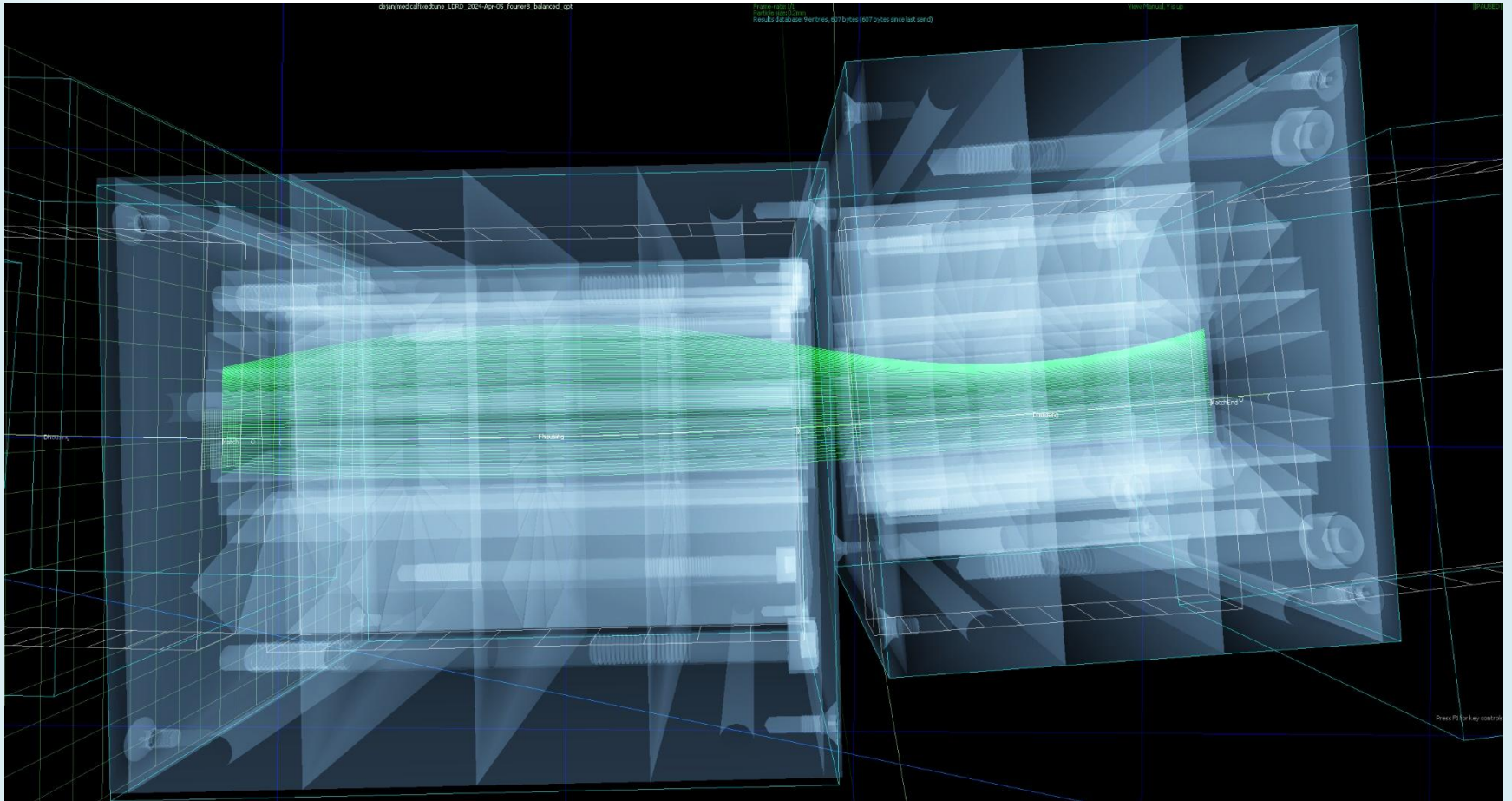

Test Beamline with Mounting

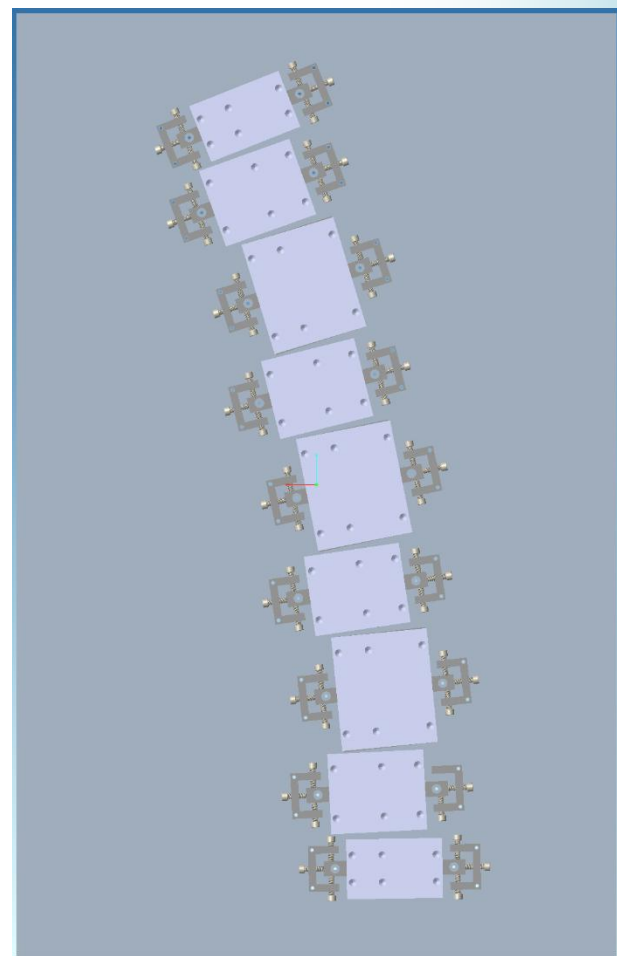
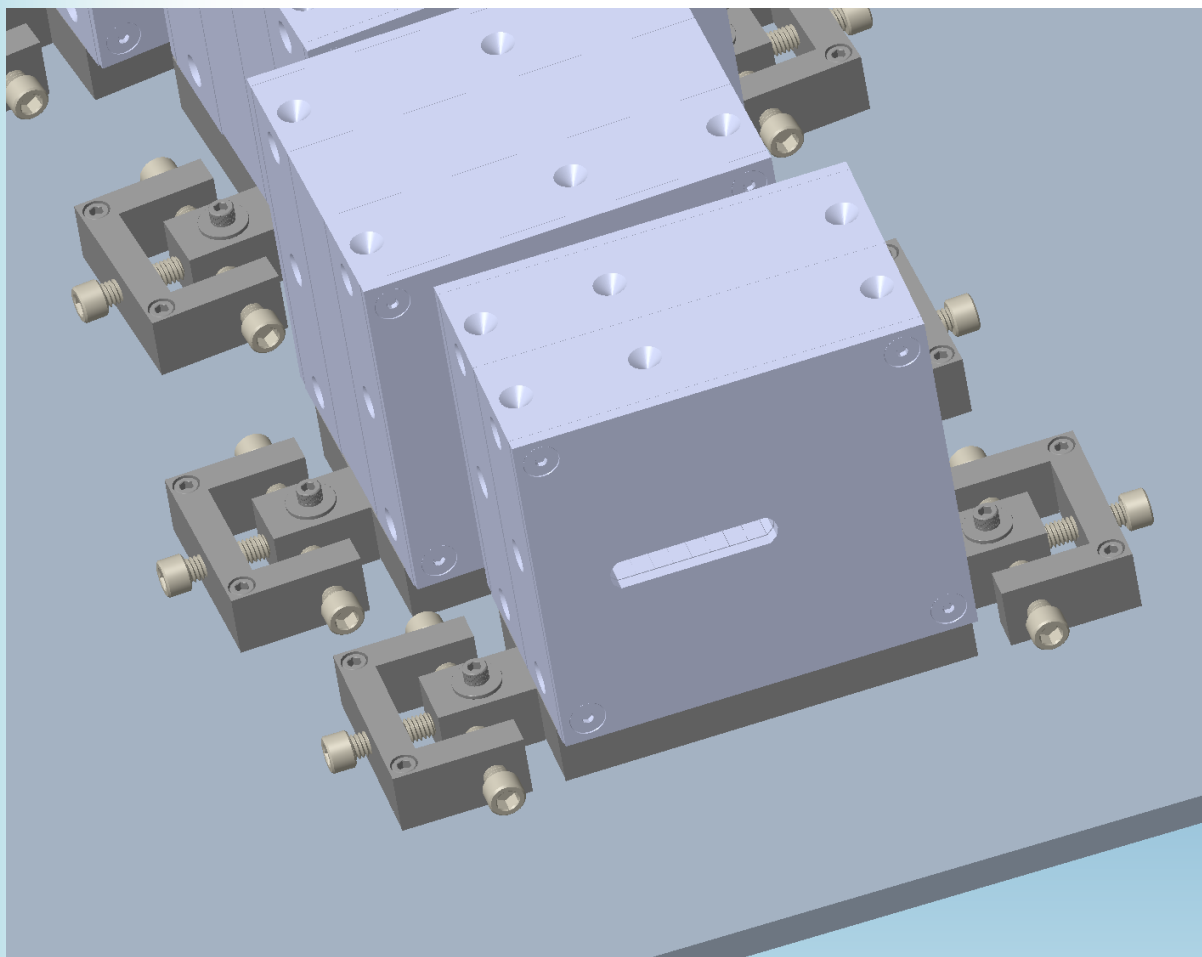

Magnet Construction by Vendor

SABR Enterprises, LLC. in Massachusetts

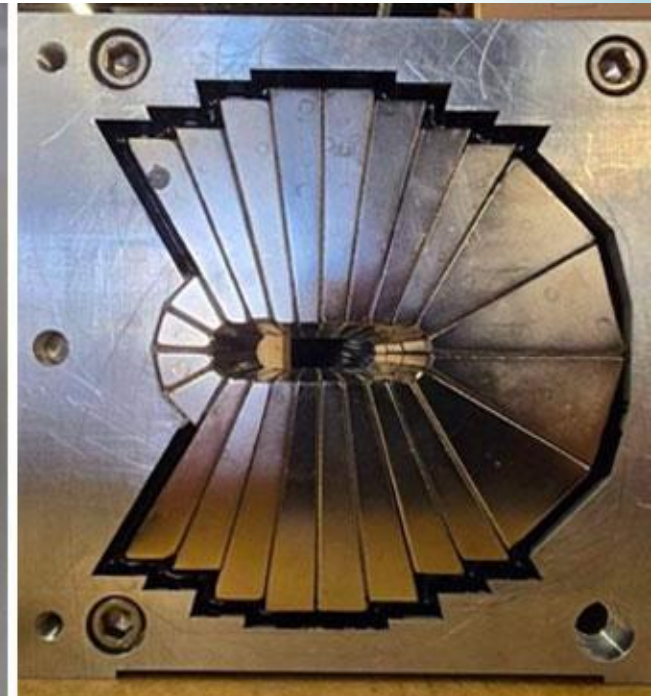
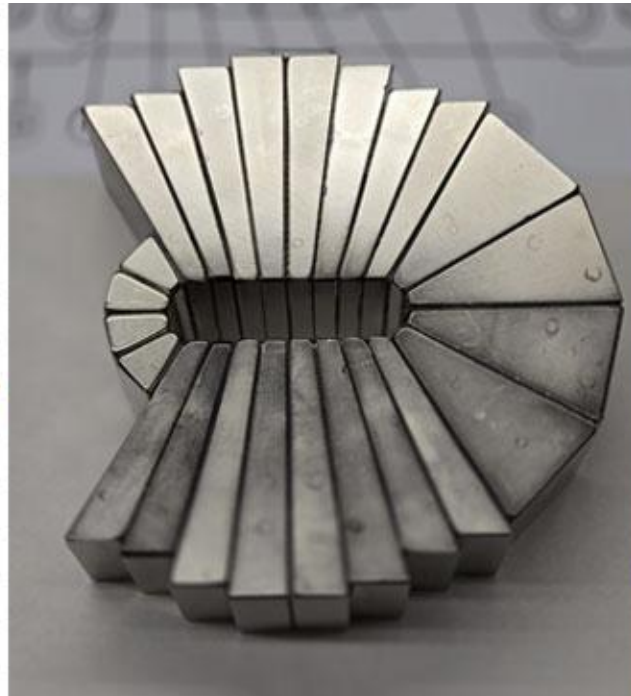
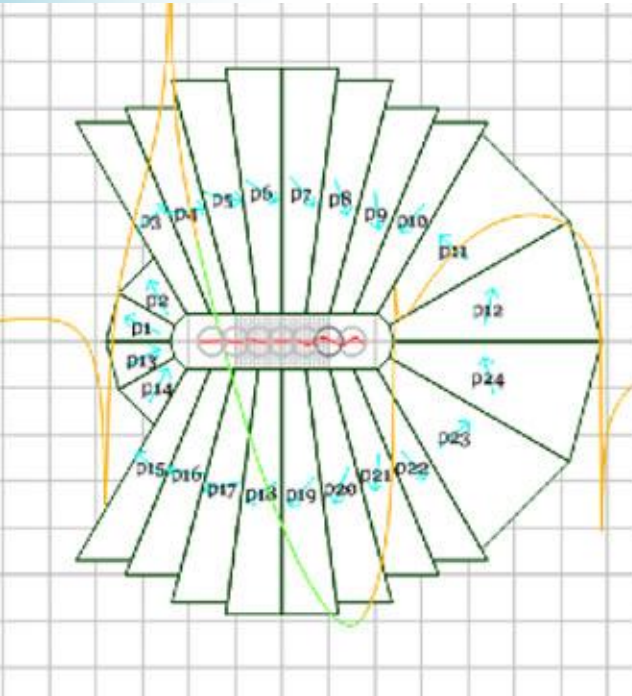

Beamline Assembly

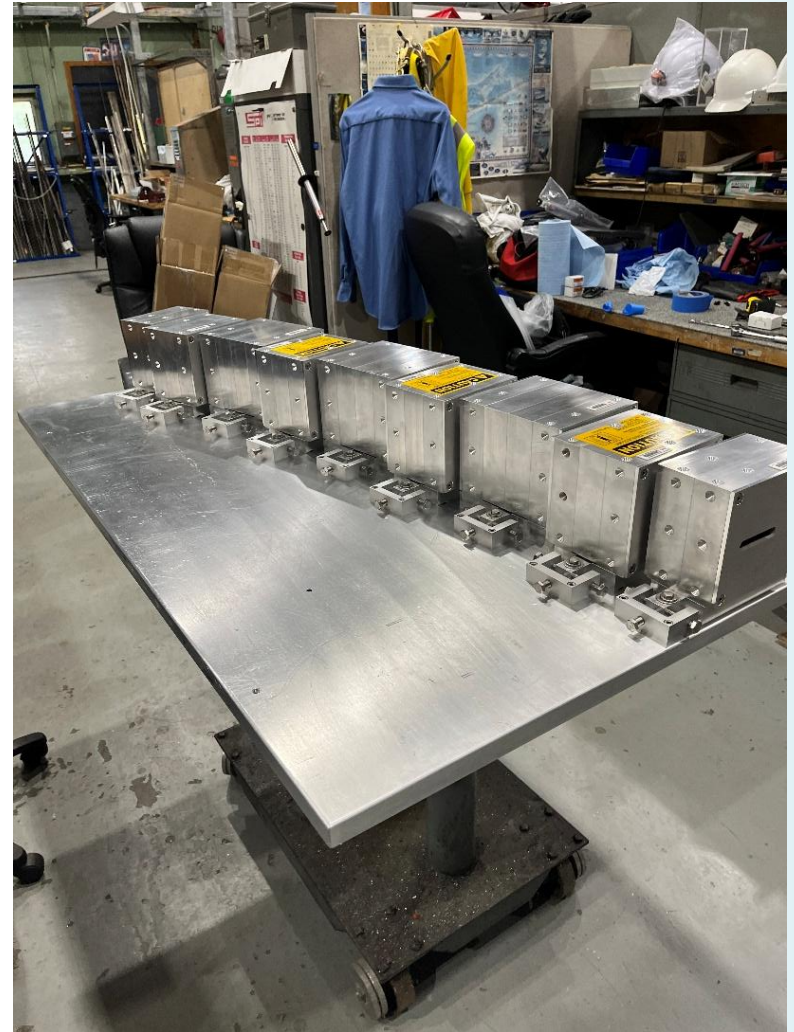

Magnet Apertures

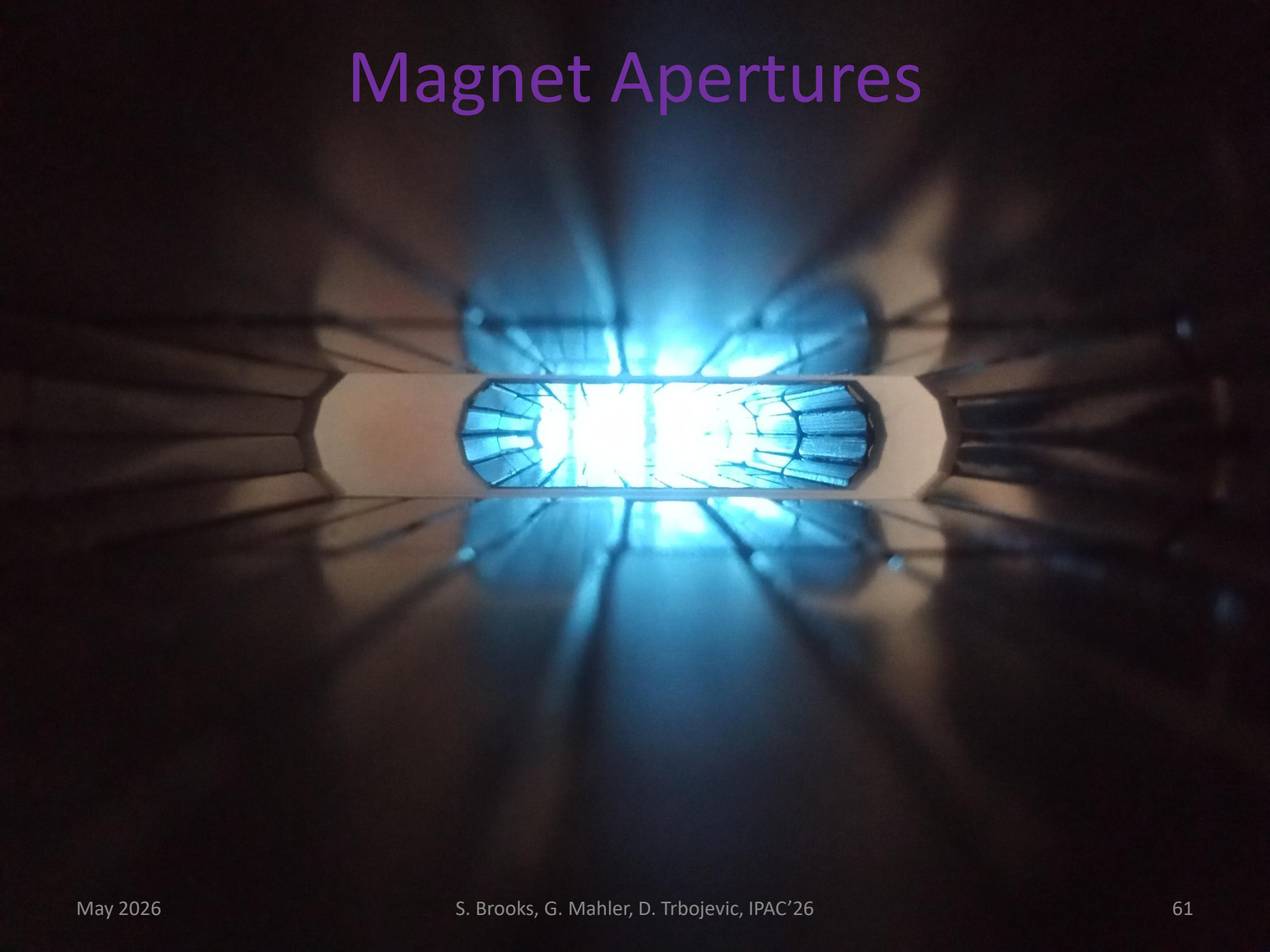

Fieldmap of one magnet

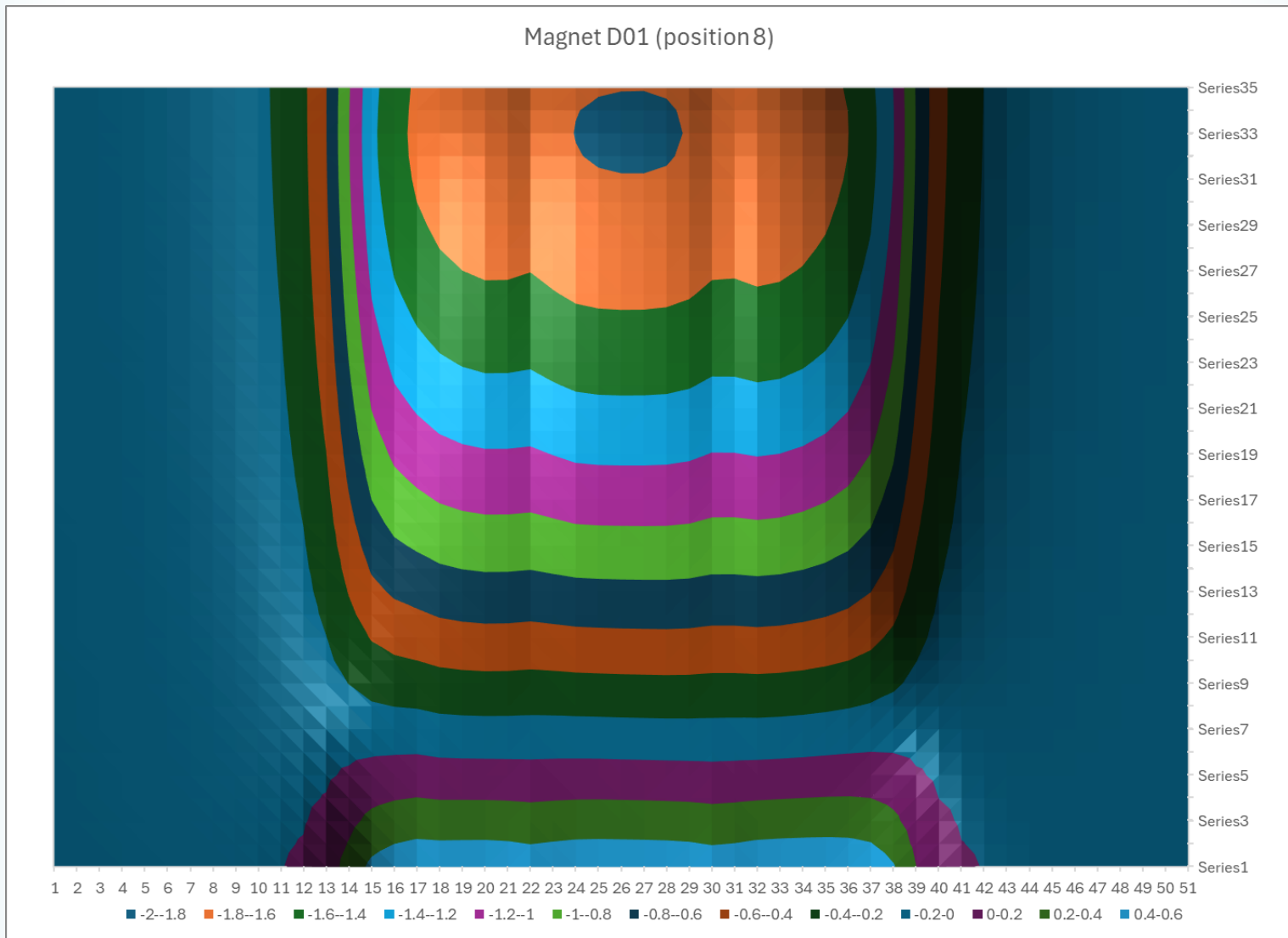

Measured Integrated Field

Corrected via fit for Hall probe displacements and tilt angles, <1% error

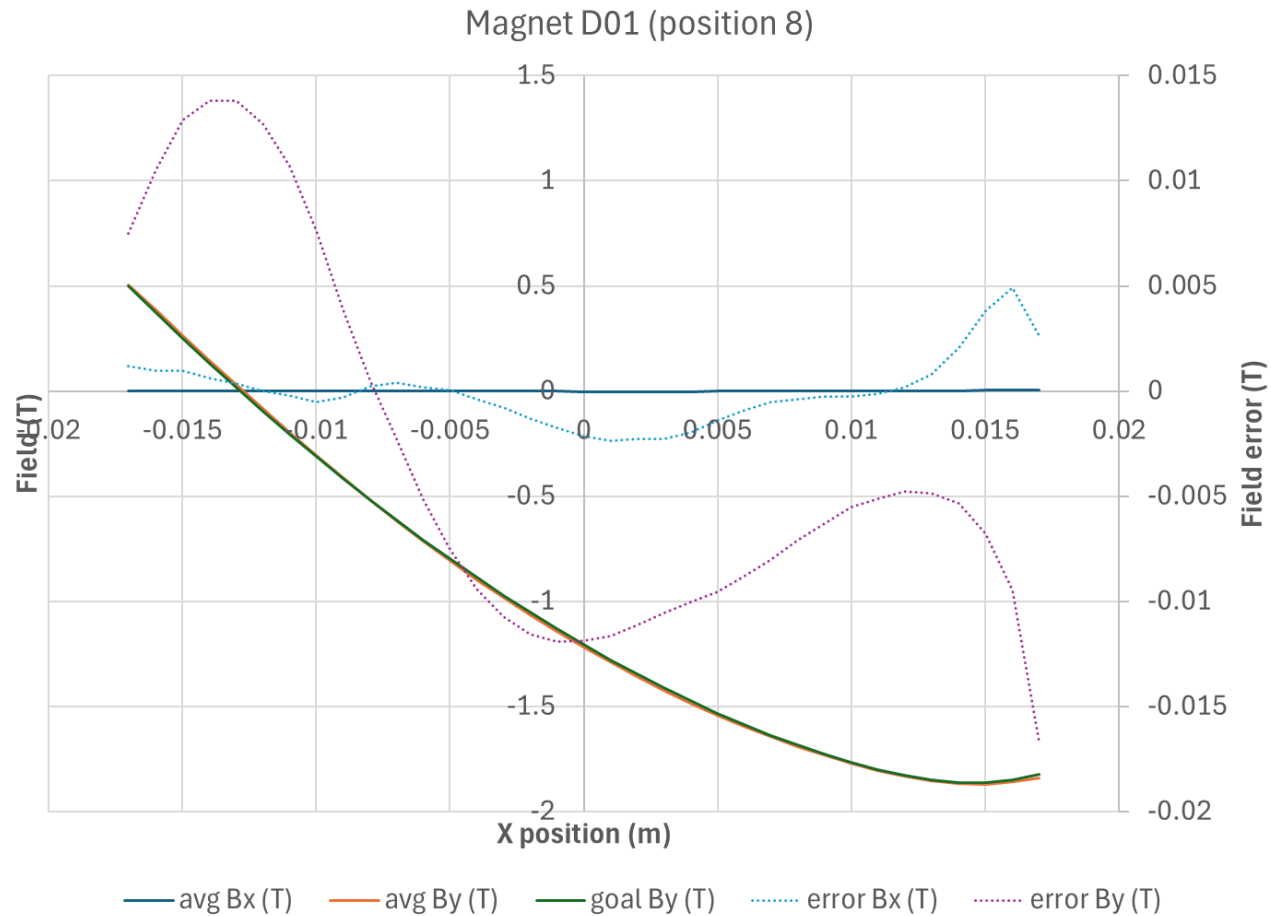

Experiment at BNL beamlines

- NSRL
 - Protons 50-250MeV
 - 1 day 2 hours
- Tandem
 - Deuterons 12.9-28MeV
 - Equivalent to protons 10-50MeV
 - Via rigidity but also window/air energy loss calculation
 - Tandem proton max energy is 28.75MeV
 - 1 day

Camera and Beam Screen Plates

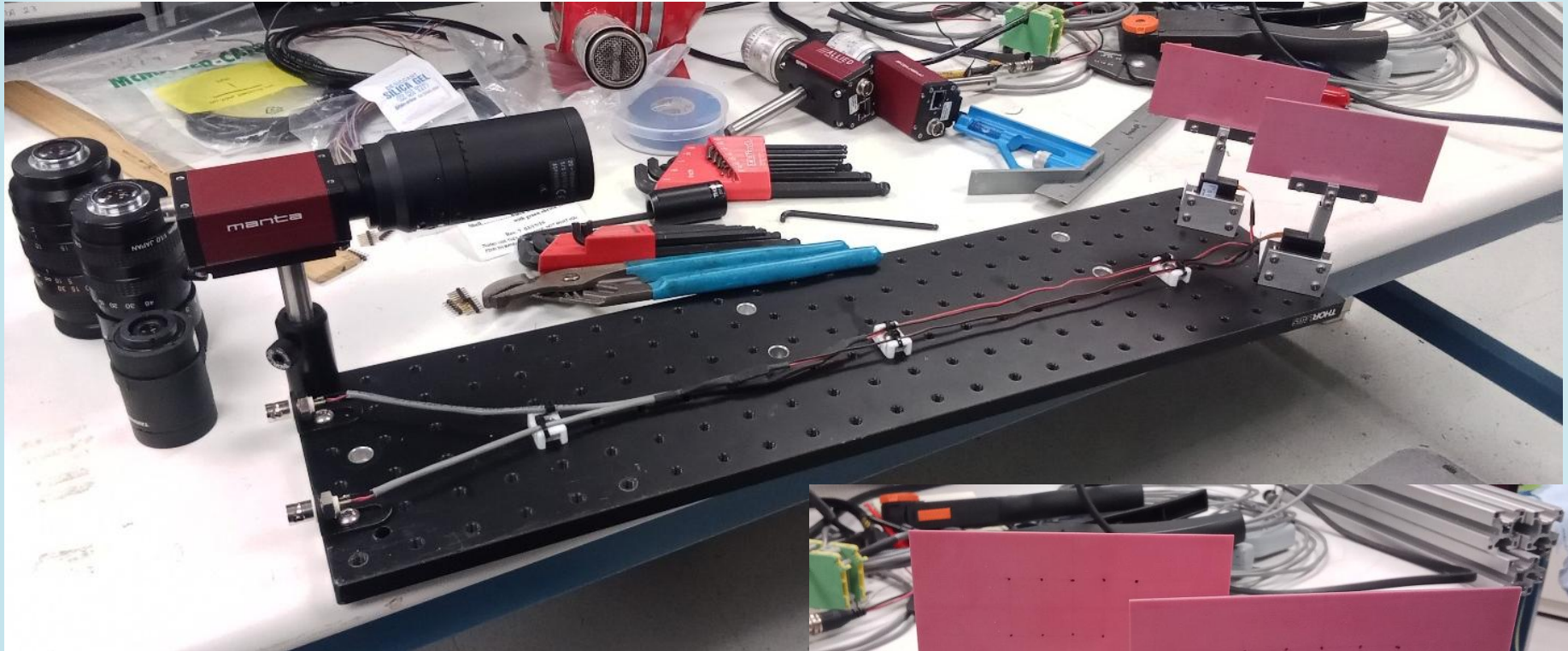

These were attached to both ends of the beamline.
4 cameras and 4 screens in total.

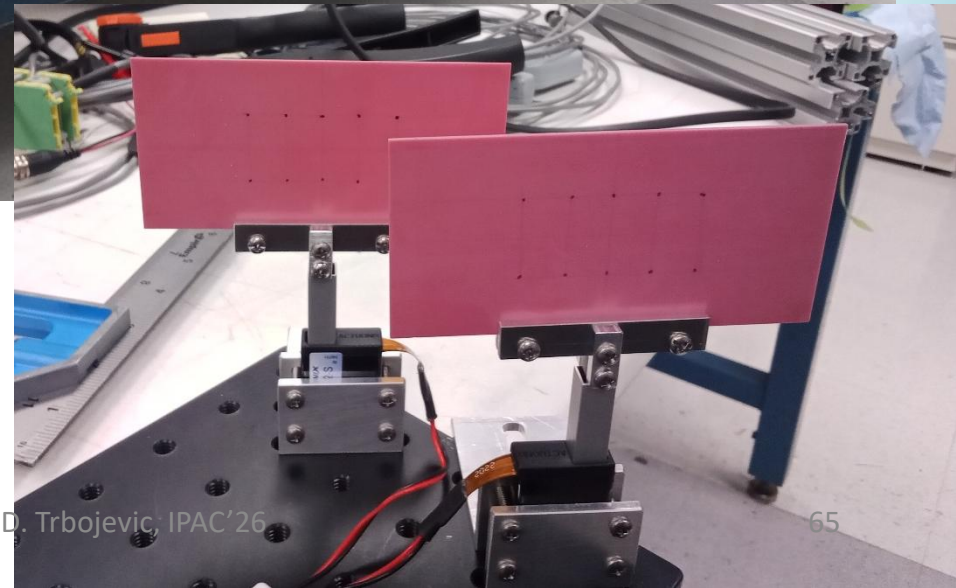

NSRL All Energies

Beam in

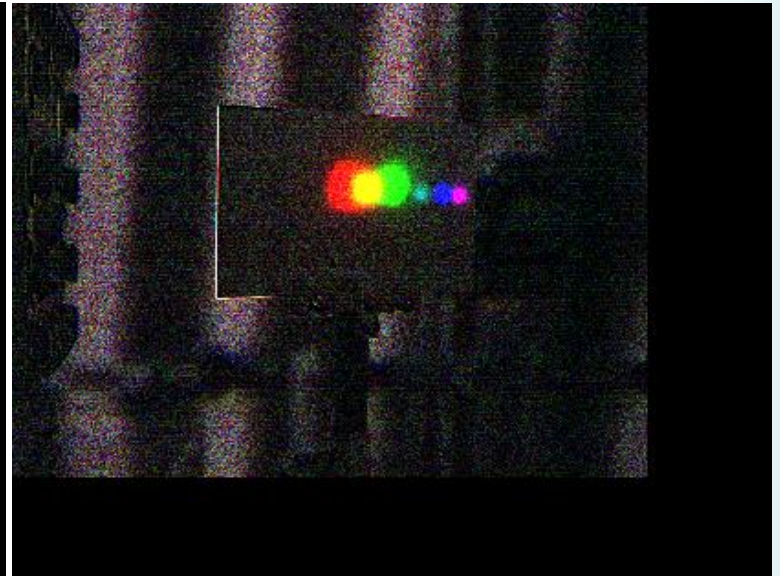

Beam out

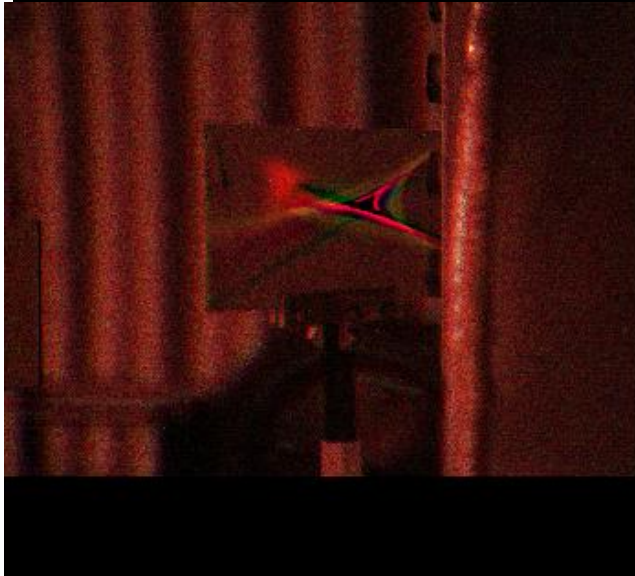

Tandem All Energies

Beam in



Beam out

All 12 Ellipses

Beam in



<energy scan> point 1 Camera 1

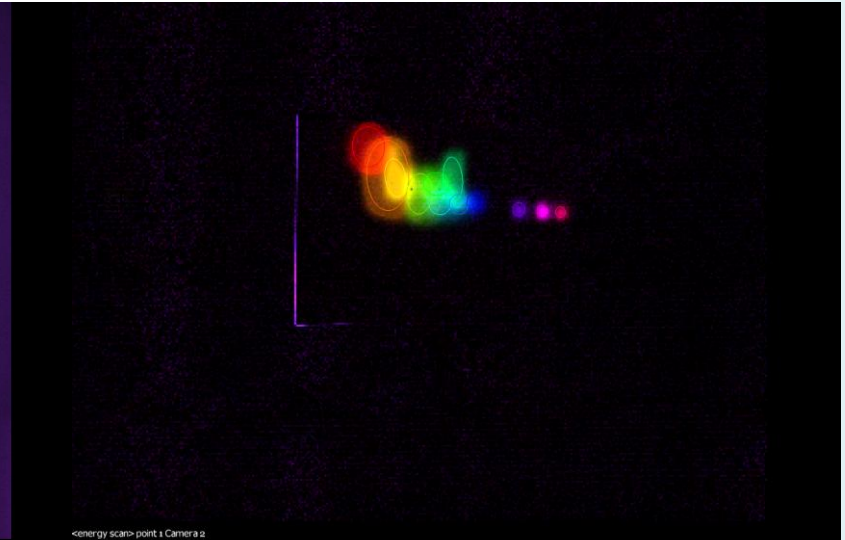

<energy scan> point 1 Camera 2

Beam out

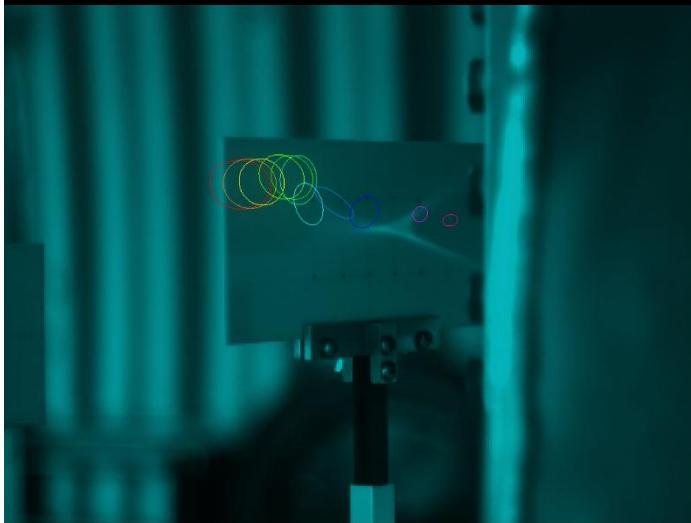

<energy scan> point 1 Camera 3

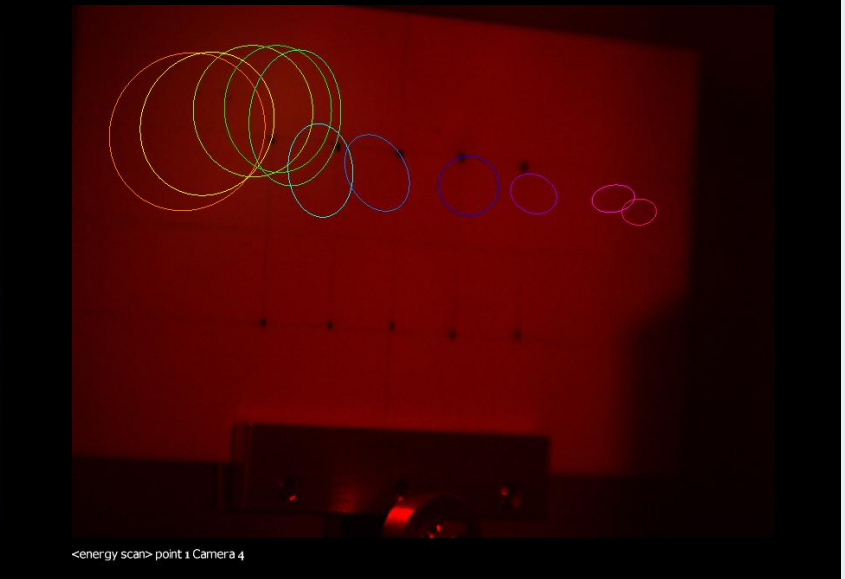

<energy scan> point 1 Camera 4

Corrected Centroid X Positions

Beam in

Beam out

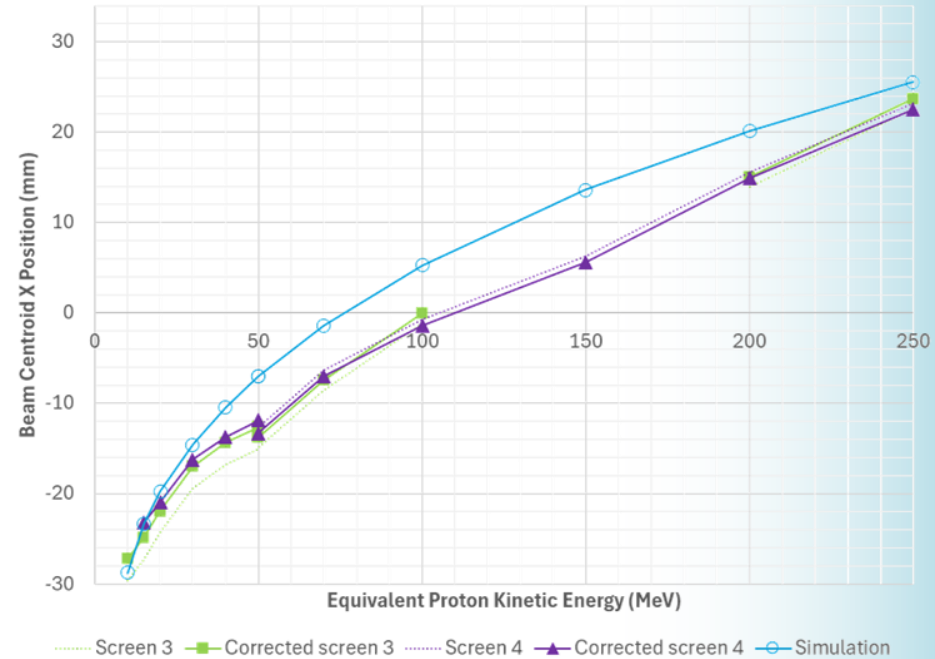
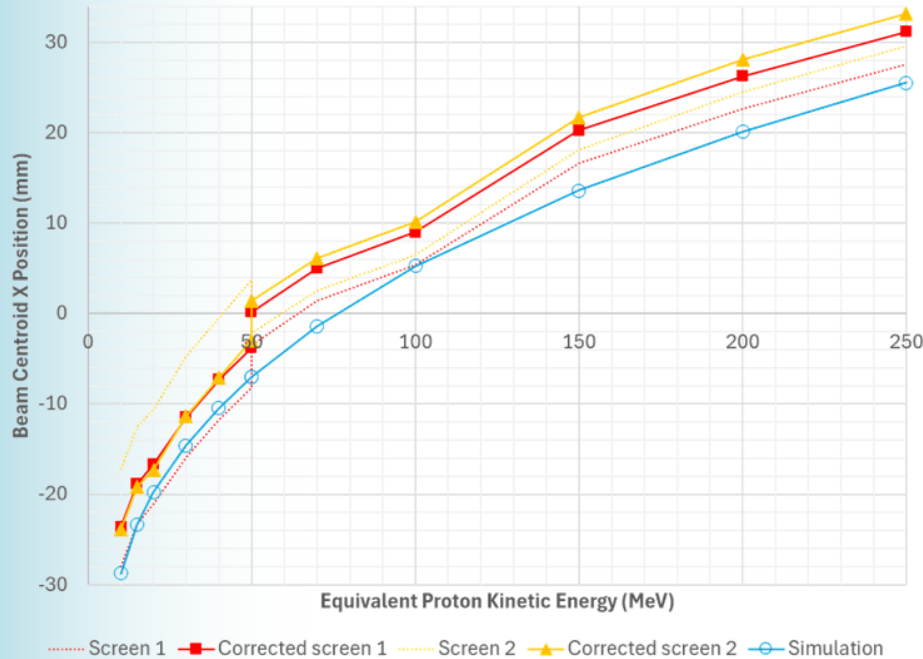

- Location tracks with energy as expected
- Alignment was “by hand”: 3-8mm input errors

Test Beamline Conclusion

- Beams at all energies were transmitted through the 4-cell test girder (22.5° or $1/8$ arc)
 - Protons at NSRL and deuterons at Tandem
- 10-250MeV is a factor of $5.3\times$ in momentum
 - Very large for a non-scaling FFA
 - CEBAF only requires a factor of $2\times$
- Beam ought to propagate several cells around a ring at the start of commissioning
 - (even without magnet shimming/correction here)

CEBAF 22 GeV Upgrade
Using two new FFA arcs
(Fixed-Field Alternating Gradient arcs made with permanent magnets.)

Still 1.1 GeV linacs
6 → 11 passes each

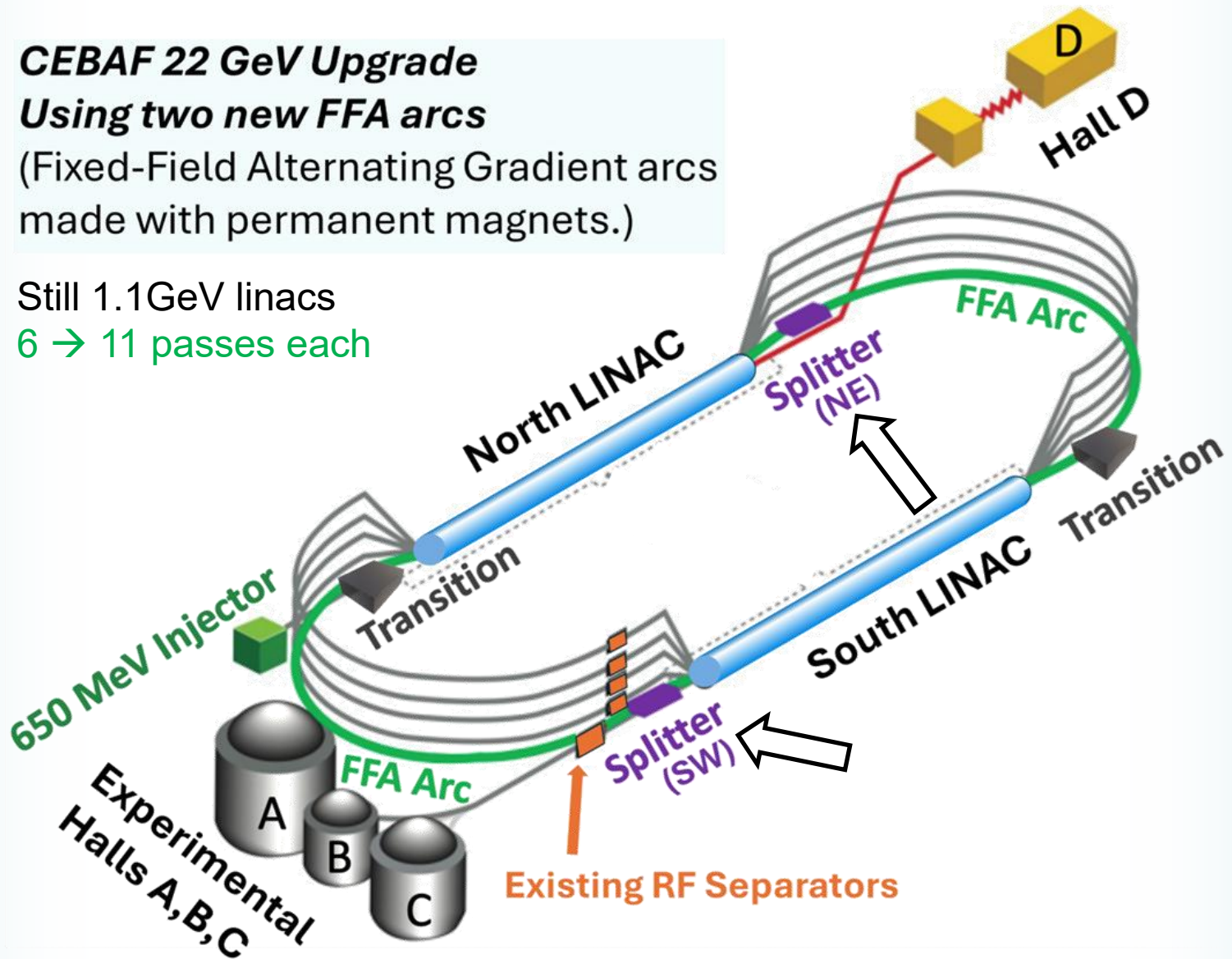

Linac-to-FFA Splitters

- Many parameters need to be matched:
 - Orbit position and angle x, x'
 - Dispersion D_x, D_x'
 - Optical functions $\beta_x, \beta_y, \alpha_x, \alpha_y$
 - Time of flight Δt
 - Energy derivative of time of flight R_{56}
- The last two in particular require separated lines to vary path length for each energy

Splitter Layout

by Ryan Bodenstein

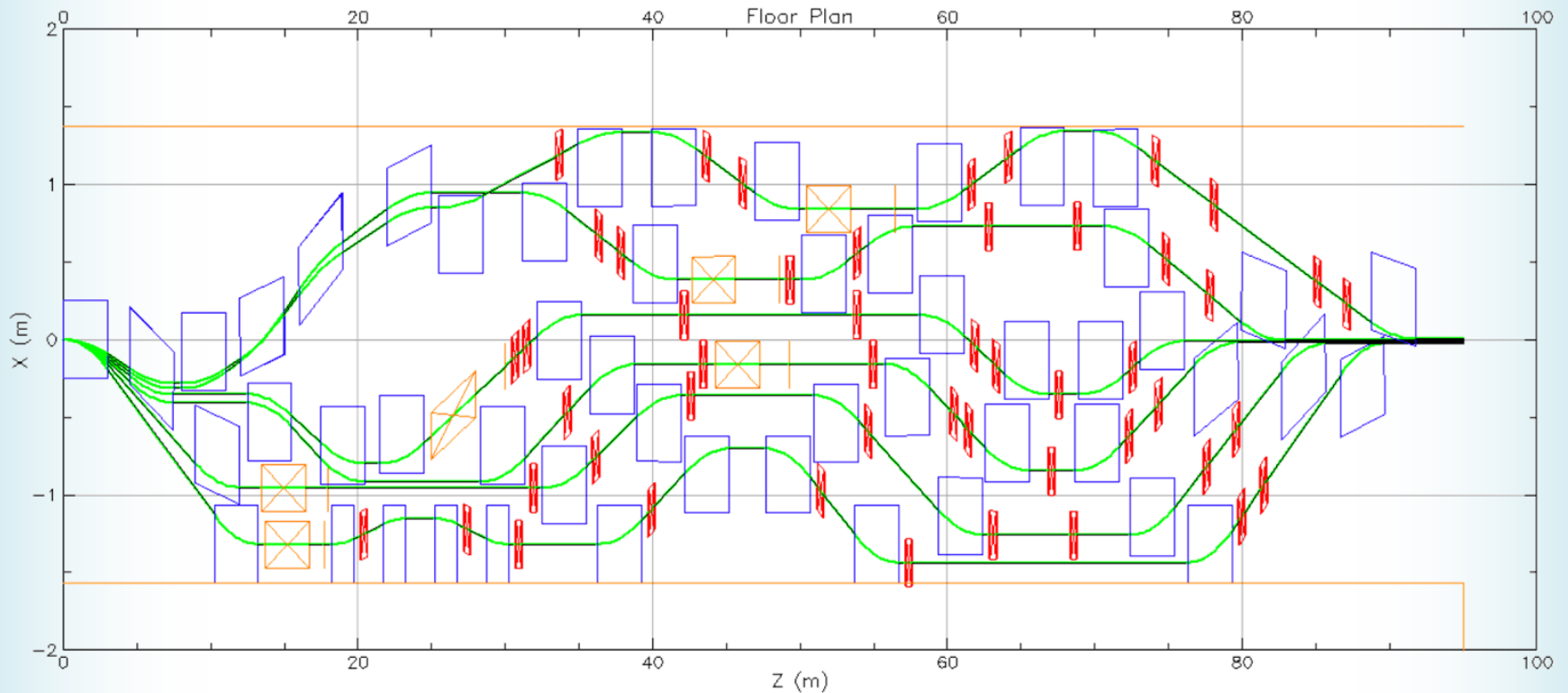

Blue = dipoles

Red = quadrupoles

Orange = extraction septa

Linac-to-FFA Splitter at CBETA ERL

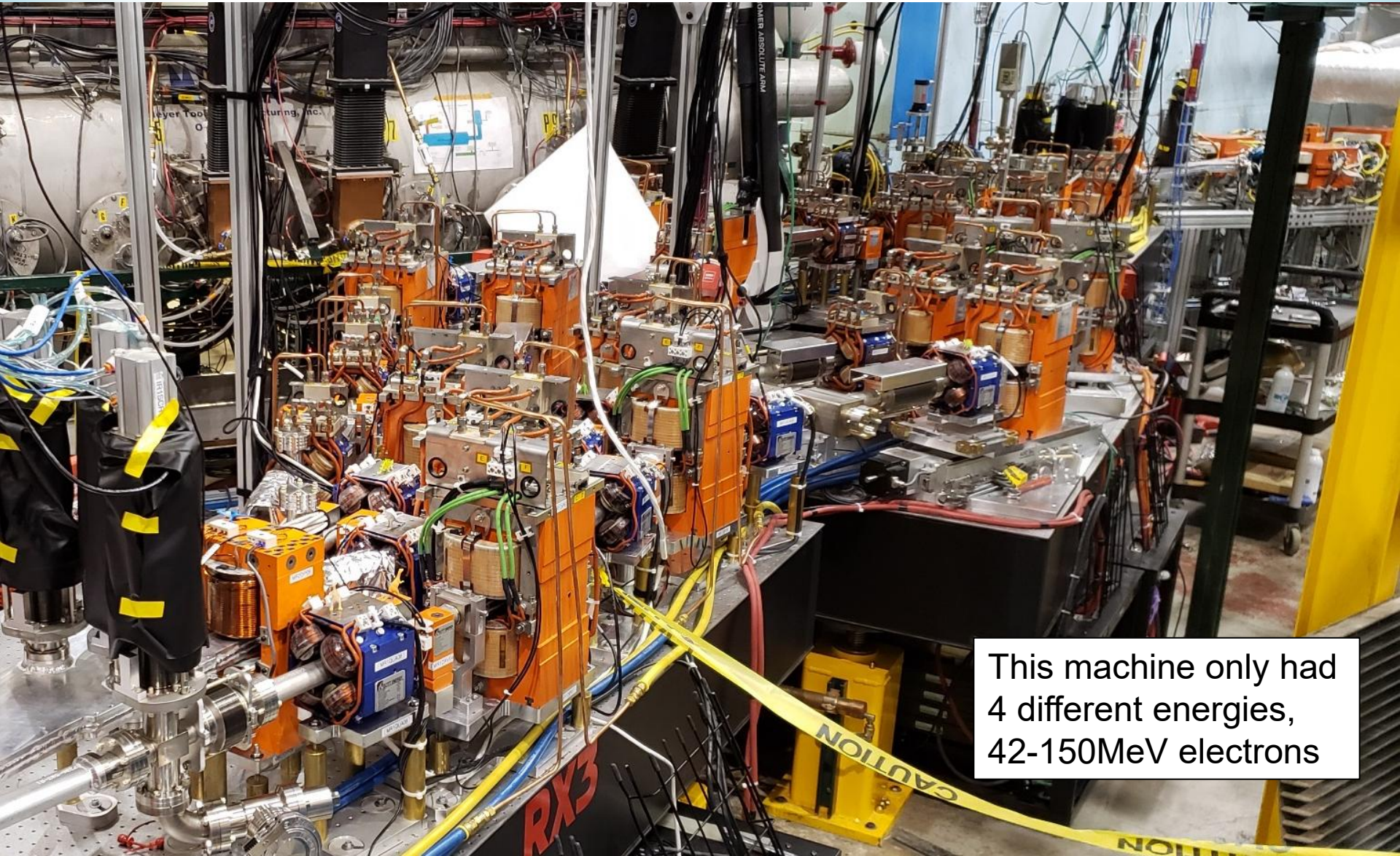

This machine only had 4 different energies, 42-150MeV electrons

CEBAF 22 GeV Upgrade
Using two new FFA arcs
(Fixed-Field Alternating Gradient arcs made with permanent magnets.)

Still 1.1 GeV linacs
6 → 11 passes each

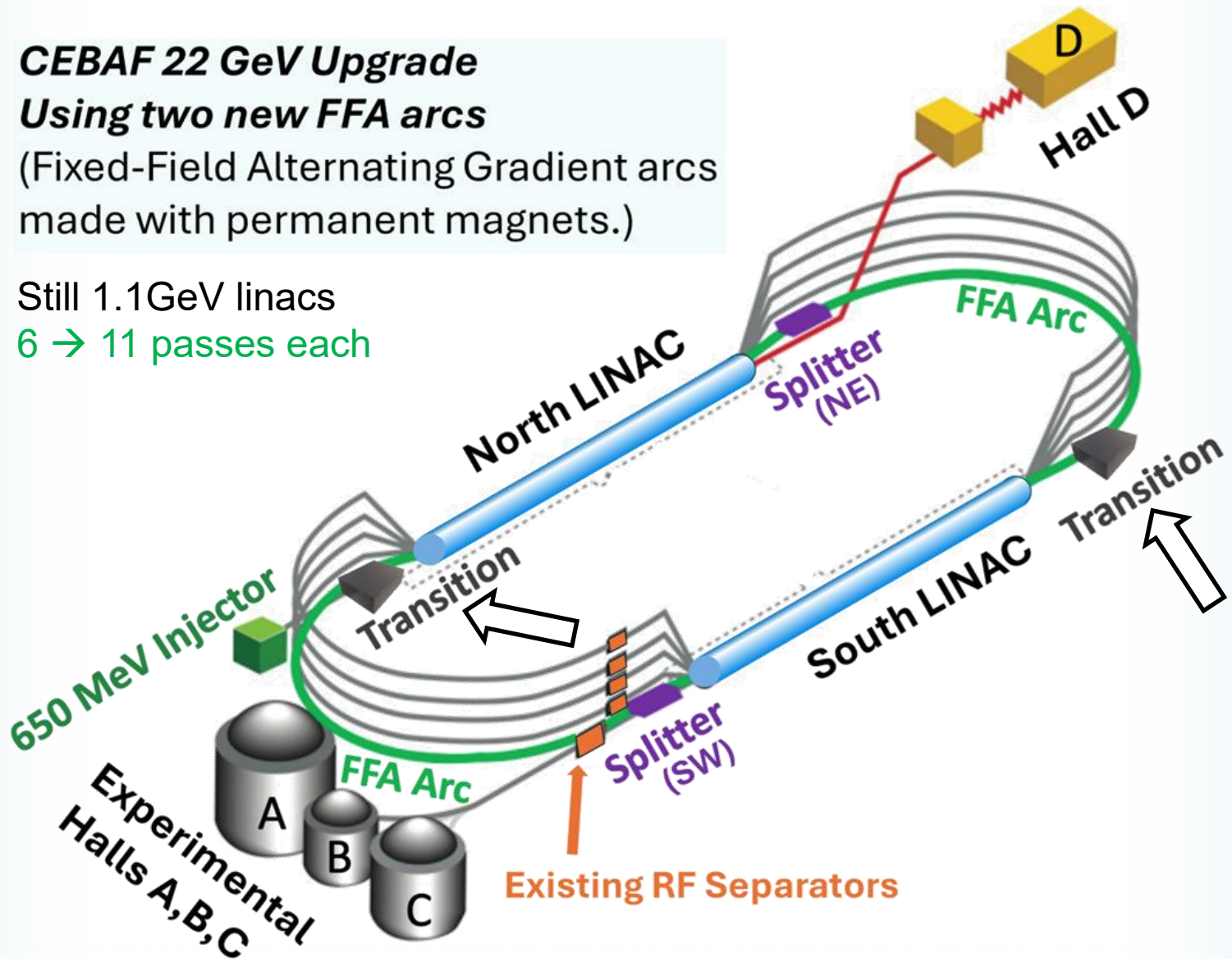

FFA-to-Linac Transitions

- To save money, only use a single line here
- Step 1: make all orbits coaxial by matching
 - Orbit position and angle x, x'
 - Dispersion D_x, D_x'
- Step 2: match all the optics simultaneously
 - Optical functions $\beta_x, \beta_y, \alpha_x, \alpha_y$
- Time of flight is dealt with in the splitter at the other end of the arc

1. Adiabatically Reduce Bending

This was also done successfully at CBETA for 4 energies

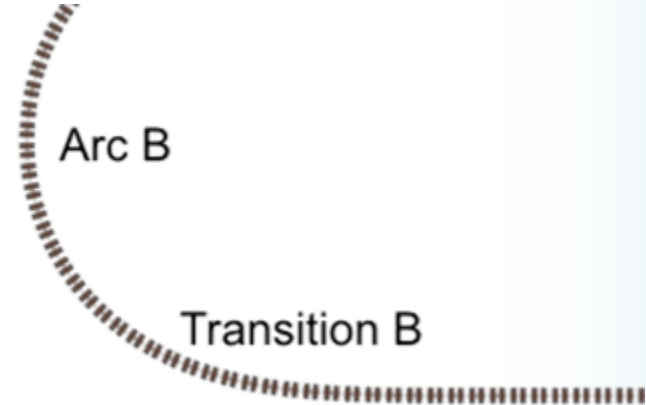
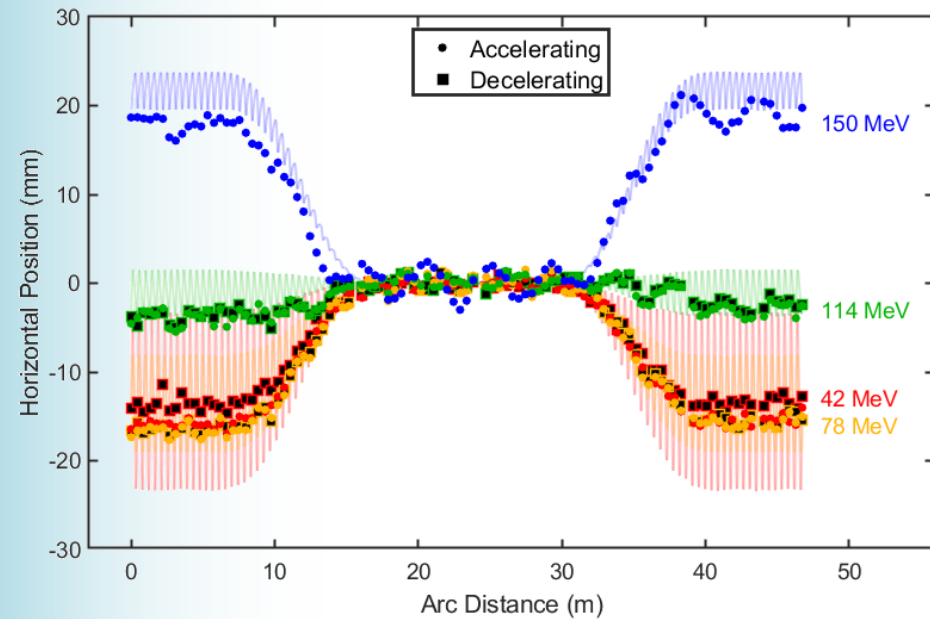

2. Six Energy Coaxial Optics Match

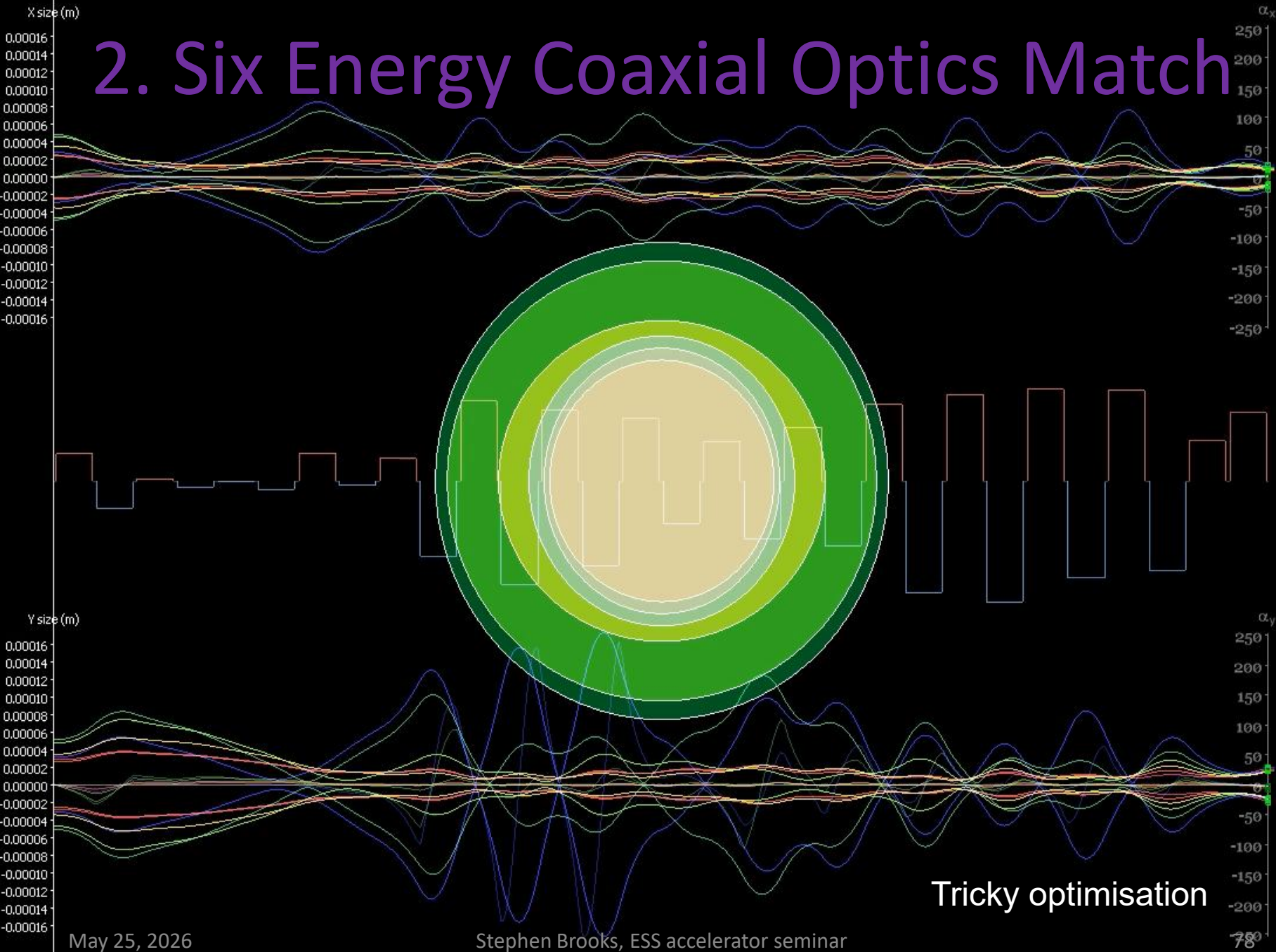

Tricky optimisation

Conclusion / Status

- Pre-CDR/‘white paper’ mostly written (65 pp.)
- Permanent magnet irradiation studies in progress (see Ryan Bodenstein IPAC’26 paper)
- Next steps are completing design of the splitters and transfer lines → end-to-end simulation
- 22GeV upgrade is quite far in the future as the Ce^+ BAF positron upgrade will happen first

BACKUP

Tripole Magnet

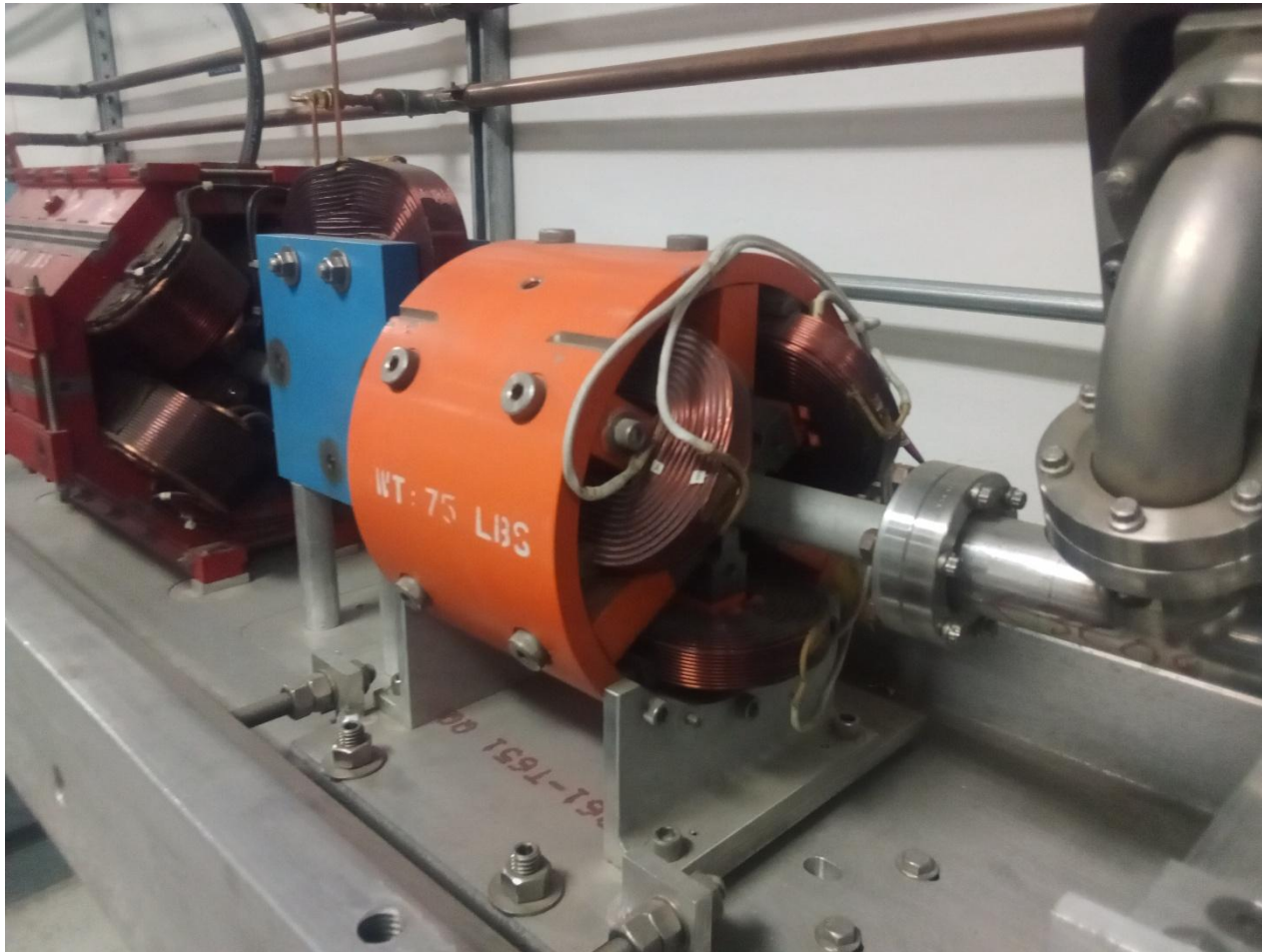

Assembly Process Notes

- Insert one half of the blocks and then flip the spiders over and insert the other half
- Make sure each block is pushed all the way in because they can repel longitudinally
 - Actually a mixture of attraction and repulsion
- The later blocks will be tighter fit but it was OK with the 0.3mm gaps (0.15mm larger mould)
 - Small gaps between some magnets were visible after central plug removed (0.1-0.2mm), inserted brass shims

Run Sequence

- Run 1: bare magnet but bad wedge alignment
- Run 2: added brass shims between wedges (better alignment)
- Run 3: added 26× 35mil \emptyset iron tuning rods but got X-axis direction definition wrong!
- Run 4: tried first tuning iteration again with corrected X axis
- Run 5: verify first tuning iteration with different rod holder but field changed
- Run 6: investigate bare magnet without tuning rods again, field had changed, wedge alignment worse perhaps
- Run 7: tuning rods first iteration based on run 6
- Run 8: 2nd tuning iteration from run 6
- Run 9: 3rd tuning iteration from run 6